



Installation and Maintenance Manual

IM 782-14

Group: Applied Air Systems

Part Number: 910379621

Date: January 2022

Destiny® Indoor Air Handler

Sizes 002 through 030

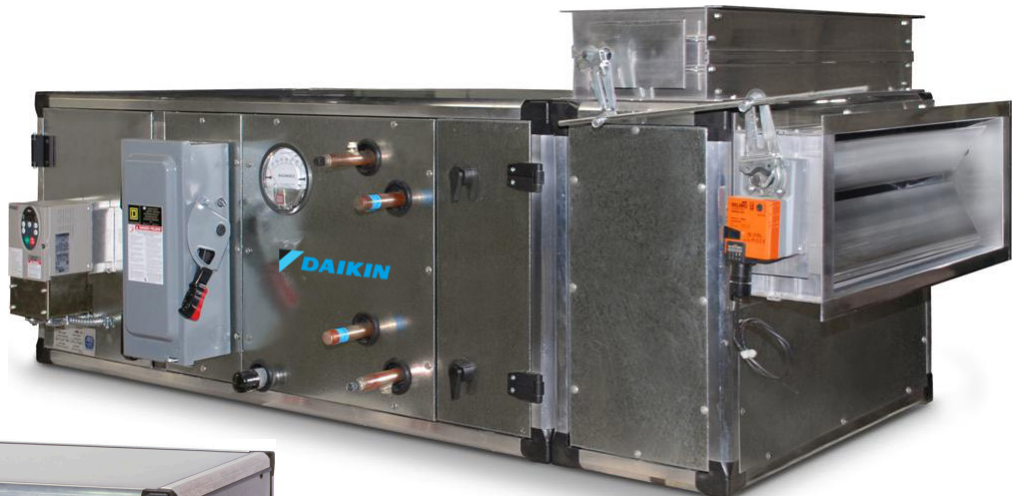

Horizontal Model



Vertical Model

Introduction	3	Physical Data	27
Hazardous Information Messages	3	Component and Section Weights	27
Smoke Control and Management Systems	3	Fan Data	30
Installation	4	Filter Data	30
Receiving and Handling	4	Coil Data	31
Storing the Unit	4	Drain Pan Data	32
Attaching the Mixing Box	5	Electric Heat Data	32
Service Clearances	6	Fan Curves	33
Rigging	7	Dimensional Data	38
Unit Leveling	7	Cabinet Dimensions—Horizontal	38
Panels and Doors	8	Cabinet Dimensions—Vertical	40
Panel Removal	8	Mixing Box Dimensions	41
Actuators	8	Electric Heat Dimensions—Left/Right Oriented	42
Installing Damper Actuator	9	Control Box Dimensions	43
Reversing the Coil Handling	10	Operation Guidelines	44
Reversing the Belt Drive Package	12	Startup Checks	44
Hanging the Unit from a Ceiling	12	Before Starting the Unit	44
Piping and Coils	13	Operating Limits	45
Water Cooling Coils	13	Fan Vibration Levels	45
Direct Expansion Coils	13	Service and Maintenance	46
Steam Coils	14	Periodic Service and Maintenance	46
Water Heating Coils	15	Ball Bearing Lubrication	46
Drain Pan Traps	15	Fan Drive Adjustments	47
Internal Isolation Assembly Adjustment	16	VM and VP Variable Pitch Key Type Sheaves	47
Spring Mount Adjustments—Twin Fan Units	16	LVP Variable Speed Sheaves	48
Electric Heat Section	17	MVP Variable Speed Sheaves	49
Field Power Wiring	21	Fan Drive Belt Adjustment	50
Variable Frequency Drive (VFD)	22	Coil Maintenance	52
Starters and Disconnects	22	Component Removal and Replacement	52
(Optional)	22	Warranty	53
Wiring Diagrams	23	Warranty Details	53
Electric Heat Diagrams	23	Warranty Return Material Procedure	53
Disconnect-Only Diagrams	24	Replacement Parts	53
VFD Diagrams	25	Destiny Equipment Warranty Registration	54
		Quality Assurance Survey	59

Hazardous Information Messages

CAUTION

Cautions indicate potentially hazardous situations, which can result in personal injury or equipment damage if not avoided.

WARNING

Warnings indicate potentially hazardous situations, which can result in property damage, severe personal injury, or death if not avoided.

DANGER

Dangers indicate a hazardous situation which will result in death or serious injury if not avoided.

NOTICE

Notices give important information concerning a process, procedure, special handling or equipment attributes.

WARNING

Improper installation maintenance can cause equipment damage or personal injury.

Installation and maintenance must be performed by qualified personnel familiar with applicable codes and regulations, and experienced with this type of equipment.

CAUTION

Destiny units are not designed to be weather resistant; DO NOT install outdoors.

DANGER

Improper ground may result in severe injury or death.

Check grounding nut tightness before connecting power to the external junction box.

DANGER

Fan motor require load protection.

Failure to provide overload protection can result in fire, property damage, electric shock, personal injury or death. Connect motor to an overload protective device rated in compliance with local electric codes.

Smoke Control and Management Systems

WARNING

Improper smoke or fume air handling can result in severe personal injury or death.

A registered professional engineer must design and approve the air conditioner and air handler application to make sure smoke and fume control meet local fire codes and NFPA requirements for the specific building application. Due to the wide variation in building design and ambient operating conditions into which our products can be applied, we do not represent or warrant that our products will be fit and sufficient for smoke and fume control and management purposes. The owner and building designer must consult a registered professional engineer to satisfy themselves in this regard.

The system design and installation must follow accepted industry practice, such as described in the [ASHRAE Handbook](#), the [National Electric Code](#), and other applicable standards. The installation of this equipment must be in accordance with regulations of authorities having jurisdiction and all applicable codes. It is the responsibility of the installer to determine and follow the applicable codes.

Receiving and Handling

1. Carefully check items against the bills of lading to verify all crates and cartons were received. Carefully inspect all units for damage when received. Report visible and concealed damage immediately to the carrier and file a claim for damage within 5 days.
2. Destiny air handler units are thoroughly inspected before leaving the factory. Install units carefully to prevent damage.
3. Leave enough space around the unit for proper maintenance, filter removal, lubrication, belt adjustment, and removal of coils, if necessary (refer to [Figure 2 on page 6](#) for service clearances).
4. Use flexible connections on the inlet and outlet duct connections of the unit.
5. For 002–010 sized ceiling hung units, spring isolation of the cabinet is recommended.
6. All fans are dynamically balanced before leaving the factory. Carefully inspect fans for rough handling that can cause misalignment or a damaged shaft.
7. Adequately pitch and trap drain line from drain pan connection.

Storing the Unit

Store unit on a level surface. If air handling units are to be stored for any period of time, it is important to rotate the fan wheel (quarterly, as a minimum) to prevent permanent distortion of drive components. Keep the fan bearings lubricated. Grease may settle in the lower part of the bearing, which may lead to oxidation on the upper portion of the bearing surface.

Store units indoors in a clean, dry environment on a level surface. Moisture, debris, and minerals can cause permanent damage to the cabinet and components. Do not allow coverings to trap moisture on the galvanized surface.

Attaching the Mixing Box

Mixing boxes ship with Destiny units as a field-installed option. Attach the mixing box to the intake end of the air handler using cleats included with the mixing box section. Install the cleats into the interior mounting frames, with the hardware included as shown in Figure 1.

Figure 1: Mixing Box Installation

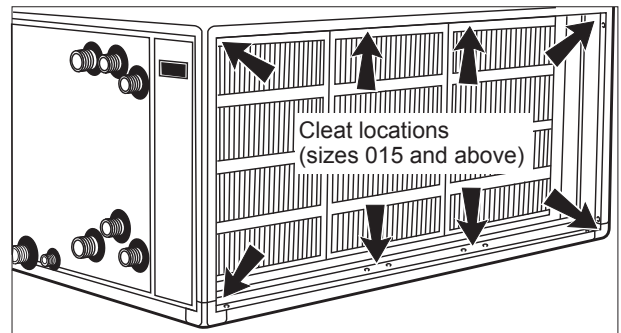
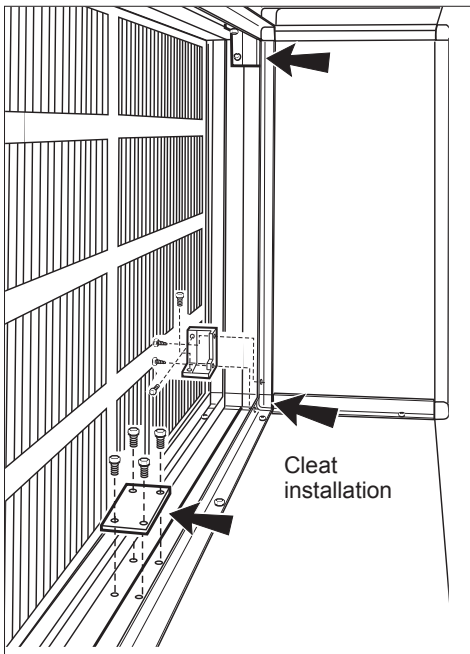
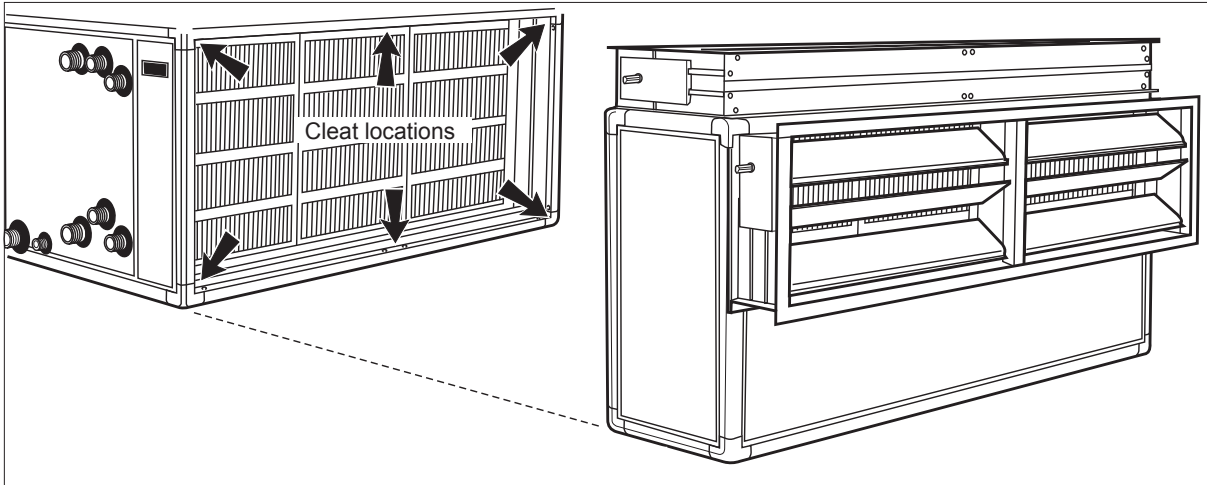

Service Clearances

Leave adequate space around the unit for piping, coils, and drains. Always have access to at least one side of the unit for regular service and maintenance. See [Figure 2](#) for servicing space requirements. Routine maintenance examples include filter replacement, drain pan inspection and cleaning, fan bearing lubrication, and belt adjustment. Provide sufficient space on the drive side of the fan and the connection side of the coil for shaft and coil removal, if necessary (refer to the "Coil Data" section in [Catalog 580](#) for information about coil sizes). Both the fan drive and coil can be field modified to right or left hand to accommodate clearance restrictions. See [Reversing the Coil Handing on page 10](#) and [Reversing the Belt Drive Package on page 12](#).

For routine maintenance, remove panels on either side of the unit. See [Panel Removal on page 8](#). Optional service doors are available for the fan and filter sections. Allow sufficient space for service door(s) to swing completely open, or to meet the clearance requirement of the section it accesses, whichever is greater. Service doors are not interchangeable with access panels on the opposite side of the unit. Determine clearances before specifying doors.

Have at least 42" of clearance in front of electrical power devices (starters, VFDs, disconnect switches, and combination devices). Electrical power devices that are mounted on the side of the unit typically are 6" deep, 12" maximum (see [Figure 2](#)).

Figure 2: Servicing Space Requirements

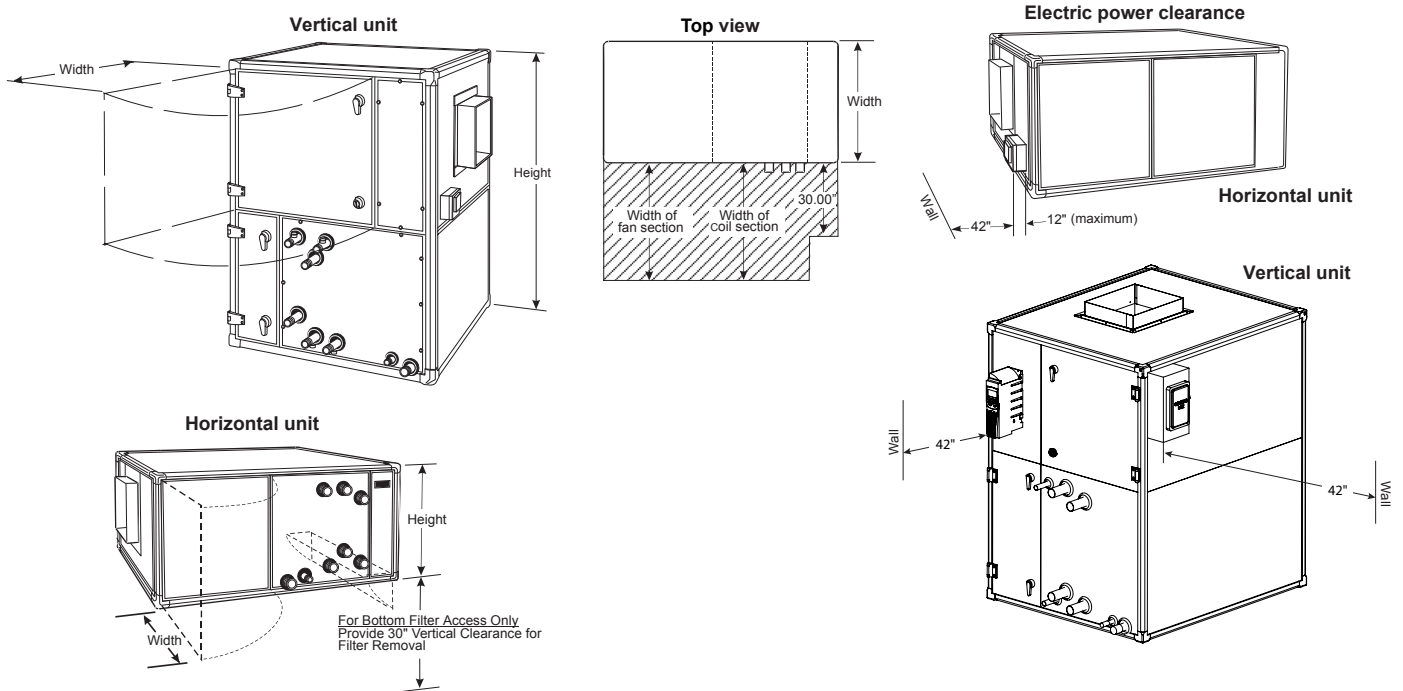

Rigging

Rig units using straps or a sling. Fasten strapping under the skid that ships with the section. If a field-installed mixing box is attached, adjust to balance the unit properly.

To avoid damage to the unit cabinetry, use spreader bars. Position spreader bars to keep cables from rubbing the frame, connections, or panels. Before hoisting into position, test lift for stability and balance. Avoid twisting or uneven lifting of the unit.

Figure 3: Rigged Unit on Skids

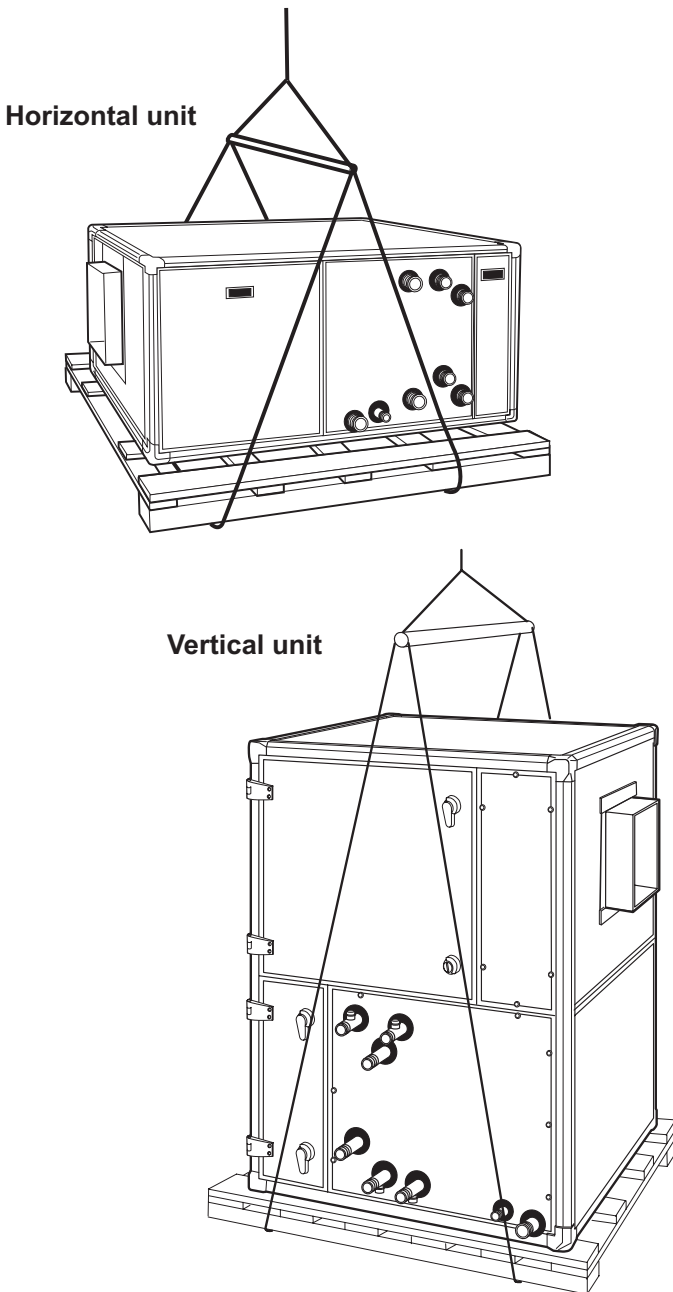

Unit Leveling

Place the equipment on a flat and level surface (or verify that unit is level when hanging from the ceiling). Where the surface irregularities allow the equipment to distort, shim the base of the unit to a straight line. Distorted units can cause misfit or binding of the doors and panels and improper draining of drain pans.

Figure 4: Leveling the Unit

Horizontal unit

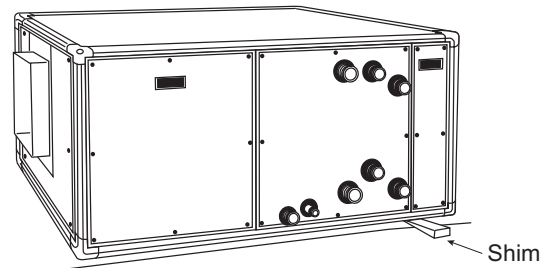

Vertical unit

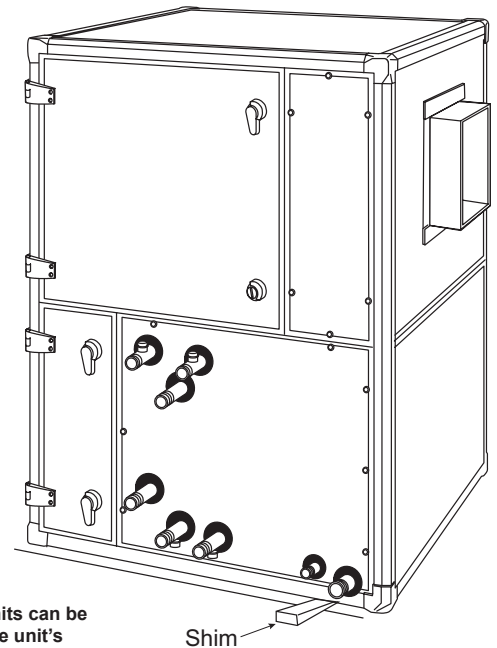

NOTE: Horizontal units can be supported only at the unit's 4 corners (e.g. by hanging rods). Vertical units must be installed on a level surface so that the unit receives support across the bottom.

Panels and Doors

⚠ DANGER

Hazardous moving parts, high static pressure, and/or high voltage. Can cause severe injury or death. Disconnect and lock ALL electric power OFF before entering or servicing unit. Unit may employ multiple power supplies and/or remote disconnects.

Secure drive sheaves to prevent motors and fan from free wheeling.

When leaving the unit, use screw or door handle locking mechanism provided to secure access panel closed and prevent unintentional entry.

Panel Removal

Destiny air handlers have pocket pull handles in alternate sections that allow side panels to be easily removed and handled. To gain access through a side panel, remove the fasteners along the sides of the panel and lift the panel off using the pocket pull handle. If the panel you are accessing does not have a pocket pull handle, remove an adjoining panel with a pocket pull handle and push the panel out from inside the unit.

Fan Section Doors

1. Use a flat head screwdriver and rotate the screw 1/4 turn as shown in Figure 6.
2. Rotate door handle 1/4 turn and open the door.

Figure 5: Panel Removal

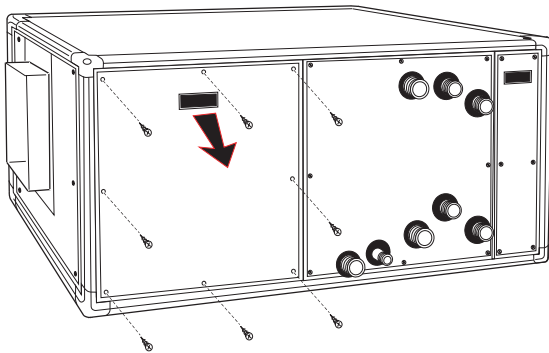
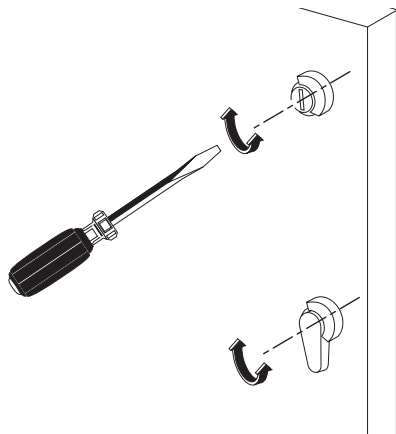

Figure 6: Fan Section Doors



Actuators

⚠ CAUTION

Maximum damper rotation is 70°. Maximum shaft torque is 205 in.-lb. Greater rotation or torque can cause equipment damage.

The factory-mounted actuator has been initially adjusted in the factory. Power and control wiring, as well as fine-tuning adjustment, is to be performed in the field.

The installing contractor is responsible for the mounting of all field-installed actuators. An actuator mounting plate is provided on the shaft side of the damper frame to accommodate many actuators. However, due to the number of options, size variations, and arrangements available, some actuators may require alternate field provided mounting hardware. Provide proper support for the actuator to avoid excessive stress in the cabinet, linkage, or damper shafts.

Fresh air and return air dampers can be linked together and driven from the same actuator if the dampers are the same size. If the dampers are different sizes, they must be driven by separate actuators and controlled appropriately.

A typical rotary electric actuator can handle up to 40 square feet of damper. For pneumatic actuators, allow 5 in.-lb. per square foot of damper area.

For good air flow control, adjust the linkage so that the damper blades do not open beyond 70°. Opening a damper blade beyond 70° will have little effect on unit performance.

Do not “over-close” the low-leak damper blades as the blades may lock up if the accompanying seal goes over the center of the adjoining blade. Instead, close the damper blades until the edge seal just lightly contacts the adjoining blade.

Figure 7: Factory Mounted Actuator

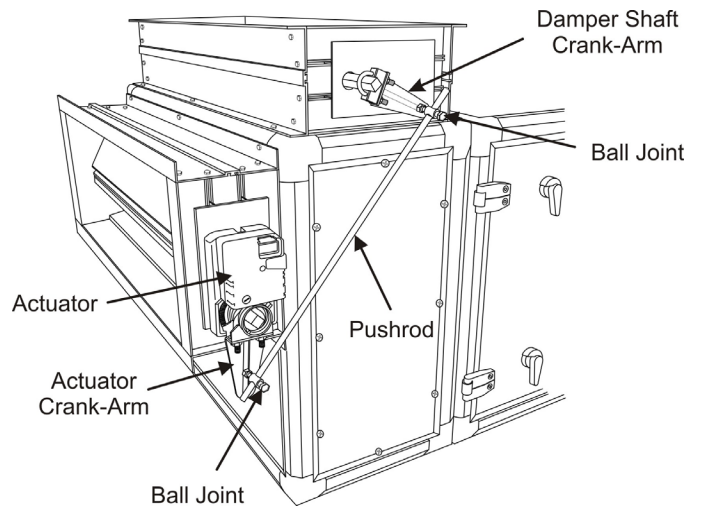

Installing Damper Actuator

1. Turn the damper shaft until the blades are fully closed.
2. Place the actuator's universal clamp over the damper shaft (Figure 8). Make sure that the controls on the actuator cover are accessible. Place the actuator in the desired mounting position.
3. Disengage the actuator gear train by pressing the manual override button (Figure 9) and rotate the clamp until centered.
4. Slide the anti-rotation strap (Figure 9) under the actuator so it engages the actuator at the center of the actuator cut out (located on the back side). Bend the bracket as needed to support the back side of the actuator. Secure the strap/actuator to ductwork with self-tapping screws (#8 recommended).
5. Loosen the nuts on the universal clamp. Press the manual override button and rotate the clamp to about 5° (Figure 10) from the closed position (1/16" to 1/8" between stop and clamp).
6. Tighten the two nuts on the universal clamp with a wrench.

Figure 8: Actuator on Damper Shaft

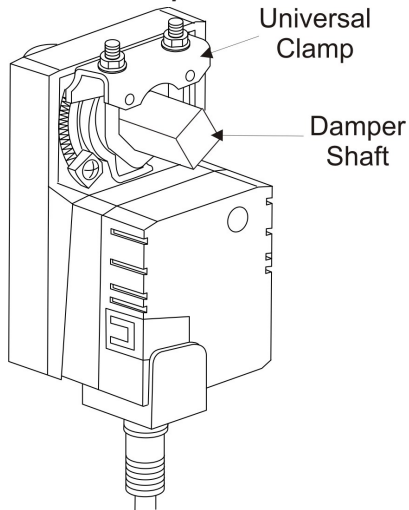

Figure 9: Actuator Manual Override Button and Strap

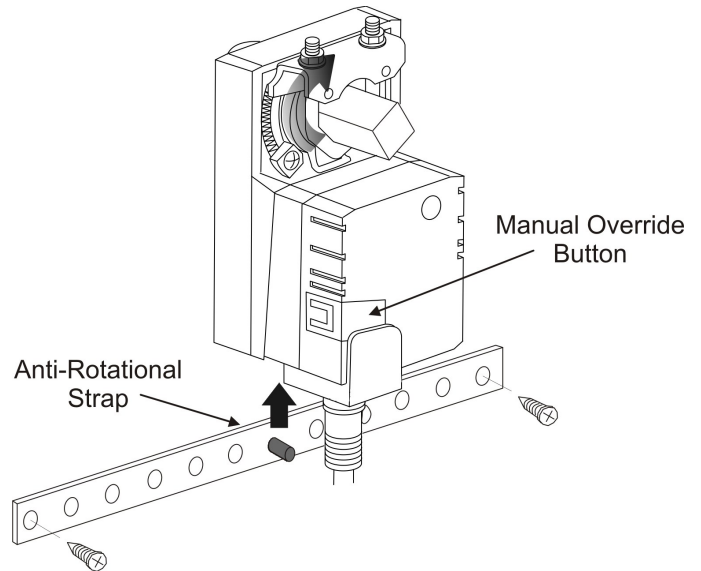
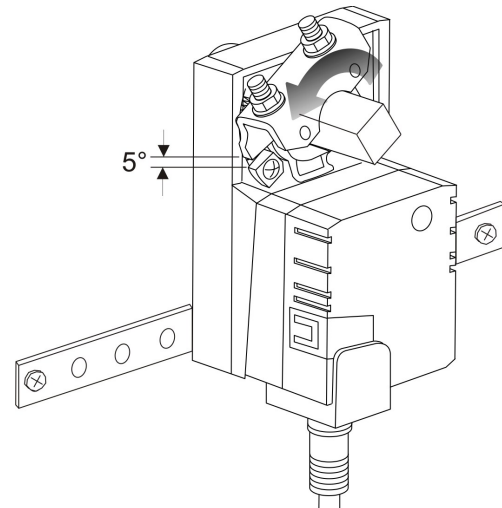

Figure 10: Actuator Universal Clamp Rotation



Reversing the Coil Handing

CAUTION

Sharp edges and coil surfaces can cause personal injury. Avoid contact with them.

Destiny coils universal-hand and coil connections can be switched to the opposite side of the unit by rotating the coil(s) 180 degrees side to side and reworking the coil section panel on the opposite side of the air handler.

NOTE: Direct expansion (DX) coils require 180 degree rotation on the top to bottom to locate distributor tubes at the leaving face of the coil.

To reverse the coil connections, follow the steps below, (also refer to [Figure 11](#)).

1. Remove exterior panels from both sides of the coil section. Remove screws that secure the top of the leaving coil face to the upper track on the inside top of the unit.
2. Lift drain pan condensate connection above the unit frame flange and slide drain pan, coil(s) and baffles out of unit.
3. Remove screws and remove coil blockoffs.
4. Remove screws holding coil to drain pan and remove coil.
5. Rotate the coil 180° and reposition coil blockoffs to the entering air side of the coil.
6. Drill holes if required and fasten the blockoffs to the entering side of the coil.
7. If unit has both heating and cooling coils, position and bolt heating coil and cooling coil casings together in same arrangement in the direction of airflow as unit was shipped from factory. Reheat coils must remain in reheat position; do not place in preheat position. Fasten the first coil in the air stream to the entering side of the drain pan using the same holes provided for the coil before it was rotated.
8. Mark locations and drill holes to align with holes in upper track.
9. Slide the coil, blockoffs and drain pan assembly back into unit the same way it was removed. Check the installation for an airtight fit. Re-install screws that secure the top of the leaving coil face to the upper track on the inside top of the unit.

Depending on whether the air handler was purchased from stock or if it was manufactured for the specific job, the panel on the opposite side may or may not have predrilled connection holes.

1. If connection holes need to be drilled, determine the proper diameter in order to use the existing grommets.
2. Mark connection locations on panel and drill new holes to accommodate connections and grommets.
3. Plug and seal unused connection holes on opposite side panel with new solid grommet or other suitable material.

Figure 11: Reversing the Coil Handing

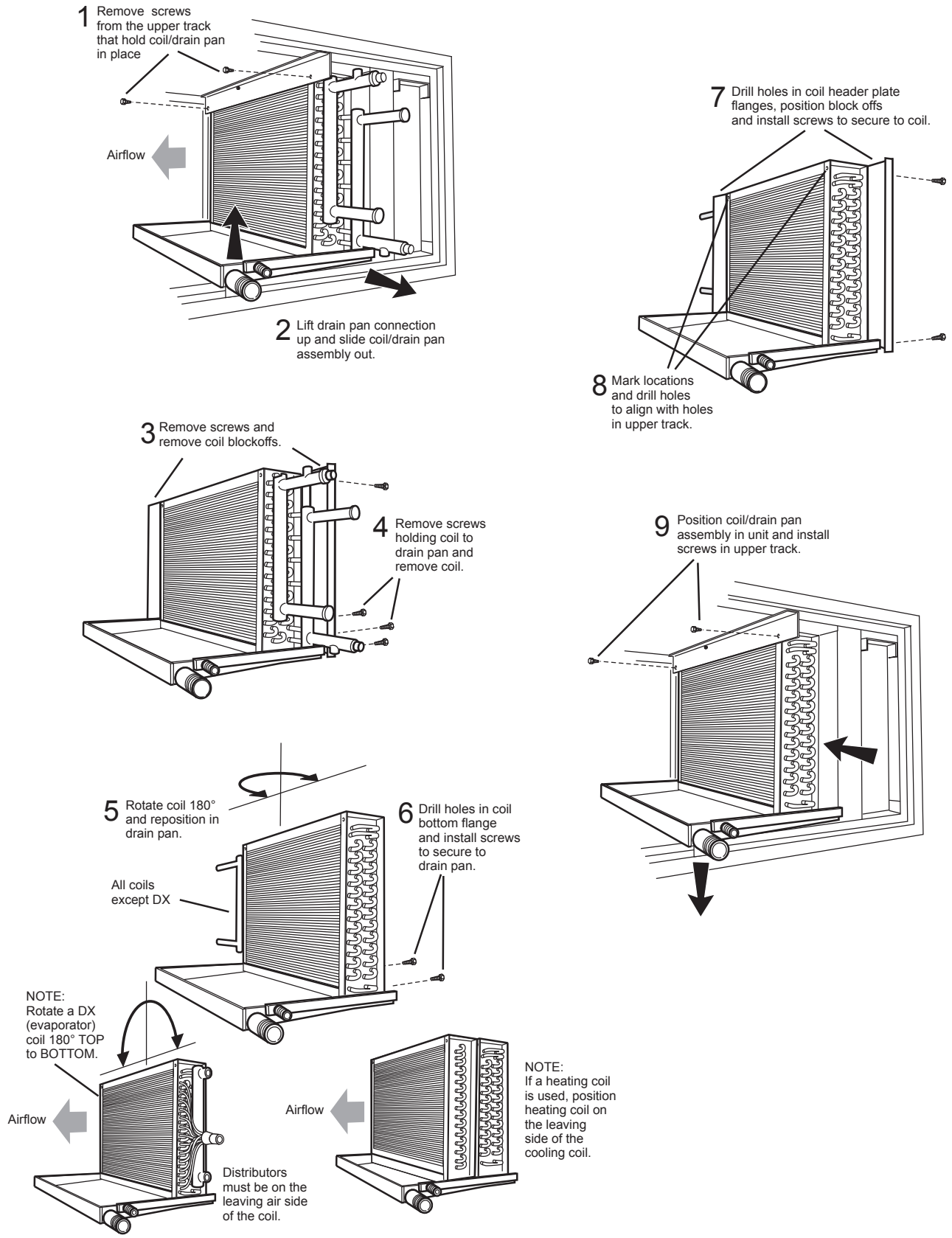

Reversing the Belt Drive Package

A motor side or “hand” is determined by looking in the direction of air flow with the air contacting the back of the head. The drive package on the air handler can be changed to the other side of the blower. The motor base and motor are attached to back of the fan housing. They can be removed, rotated 180 degrees, and reattached. The fan sheave can be removed and reinstalled on the opposite end of the shaft (Figure 12). Review [Fan Drive Adjustments on page 47](#) when reinstalling the belts.

To reverse the drive package:

1. Loosen the belt adjustment screws to relieve the drive belt tension.
2. Remove the drive belt and the blower pulley.
3. Loosen the two upper bolts on the motor mounting plate and slide the motor out from the blower housing mount.
4. Move the top motor mounting bolts to the bottom motor mounting plate location and vice versa. Fasten securely.
5. Turn the motor 180° and slide it back into the blower housing mount and tighten bolts.
6. Install the blower pulley and the belt to the other side of the blower housing.
7. Adjust belt tension.

NOTE: Change the motor wiring so the motor rotates in the opposite direction.

Figure 12: Reversing the Drive Package

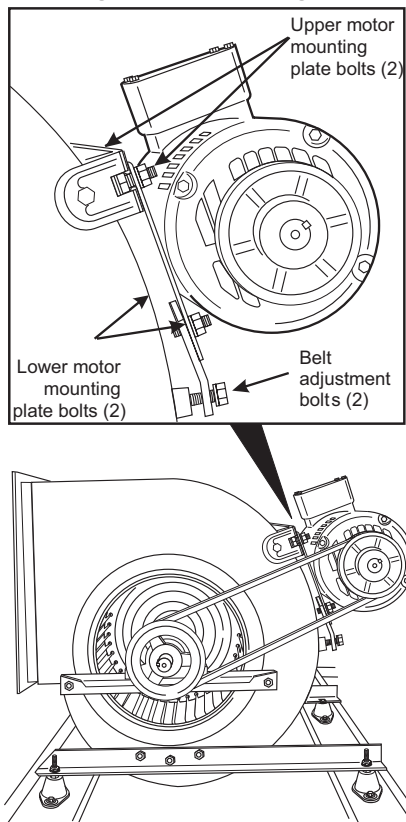

Hanging the Unit from a Ceiling

WARNING

Do not suspend the unit from the top. The unit top will not support the weight of the unit. Equipment damage and severe personal injury can result.

Before hanging, rig and completely assemble the unit. The Destiny air handler has circular knockouts on the corner connections. Remove the knockouts and suspend the unit using threaded rods and hardware (by others) with required C-channels (by others) on both sides as shown in Figure 13. On unit sizes 007 and larger, L-channels (by others) are required on both ends in addition to C-channels. For 002 - 010 sized ceiling hung units, spring isolation of the cabinet is recommended.

Figure 13: Ceiling Hung Installation, Horizontal Units Only

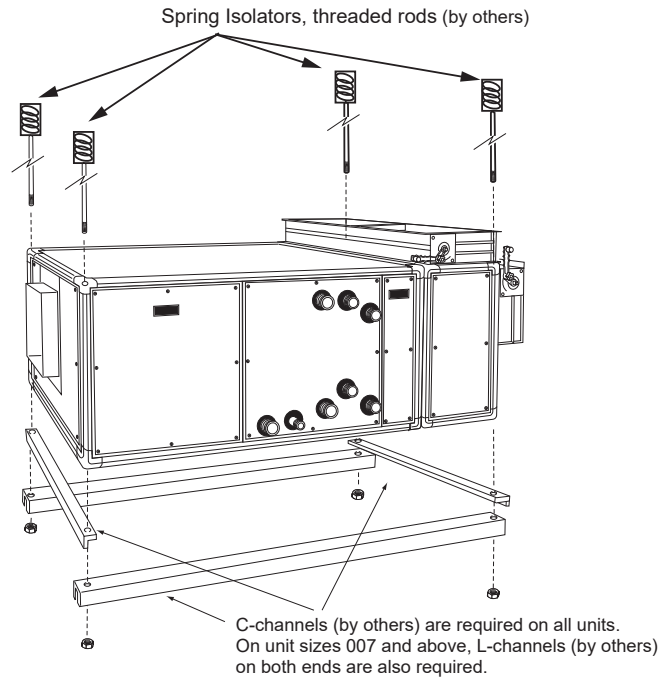
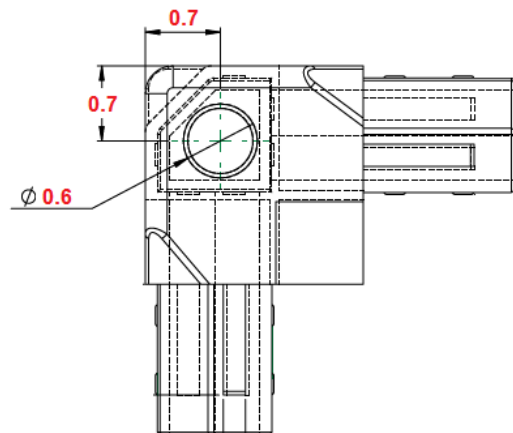

Figure 14: Hanger Bracket Mounting Location (Inches)



Piping and Coils

Follow applicable piping design, sizing, and installation information presented in ASHRAE Handbooks in the design and installation of piping. Observe all local codes and industry standards. Do not apply undue stress at the connection to the coil headers. Support pipe work independently of the coils.

NOTE: Destiny cooling coils are supplied as universal-hand coils. The coils feature four water piping connection stubs for hydronic coils and two suction line connections for DX coils. The connections to be used are clearly marked with labels. Keep other (unmarked) connections capped. Refer to [Figure 15](#) and [Figure 16](#), detailing the correct stubs that are to be connected to the system piping.

Water Cooling Coils

Water cooling coil guidelines are listed below. Also, refer to [Figure 15](#).

1. Water supply, water return, drain, and vent connections extend through the end panel of the coil section. All connections are labeled on the end panel.
2. Water supply and water return connections are copper sweat on units 002 through 010 and male NPT iron pipe on units 015 through 030.
3. When installing couplings, do not apply undue stress to the connection extending through unit panel. Use a backup pipe wrench to avoid breaking the weld between coil connection and header.
4. Follow recommendations of the control manufacturer regarding types, sizing, and installation of controls.

Figure 15: Water Cooling Coil Connections

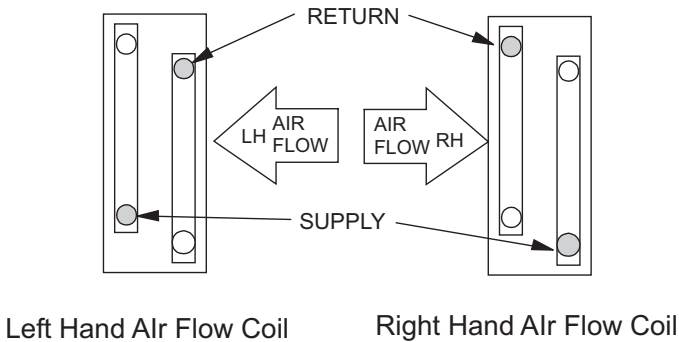

Direct Expansion Coils

Direct expansion coil connection guidelines are listed below. Also, refer to [Figure 16](#).

1. The coil distributor and suction connection extend through the end panel of the coil section.
2. Check nozzle in distributor for proper tonnage.
3. The thermostat expansion valve must be an external equalizer tube type. Connect the equalizer tube provided on the coil (3/16" for units 002 to 010, and 1/4" for units 015 to 030) to the connection on the expansion valve.
4. Use care when piping up the system, making sure all joints are tight and all lines are dry and free of foreign material. For typical refrigerant piping, see the condensing unit product manual.

Figure 16: DX Coil Connections

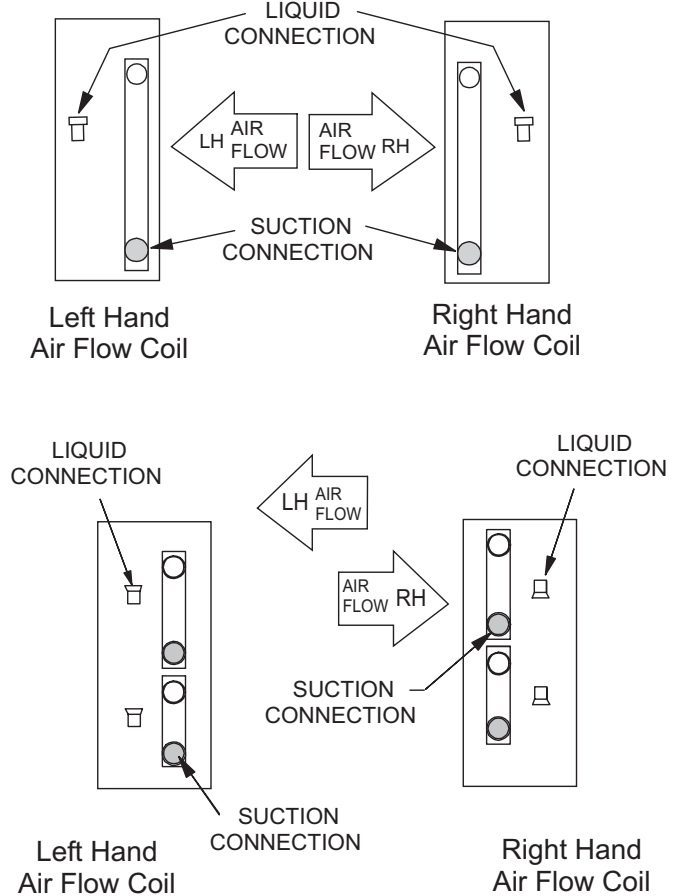

Steam Coils

(provided as Specials only)

Steam coil connection guidelines are listed below. Also, refer to Figure 17.

1. All steam coils are non-distributing (freeae) type. They are not designed to be used in 100% OA applications.
2. Steam supply and steam return connections are typically male NPT iron pipe and are labeled on the end panel of coil section. Connections extend through coil section end panel.
3. When installing couplings, do not apply undue stress to the connection extending through unit panel. Use a backup pipe wrench to avoid breaking the weld between coil connection and header.
4. Support piping independently of coils and provide adequate piping flexibility. Stresses resulting from expansion of closely coupled piping can cause serious damage.
5. Do not reduce pipe size at the coil return connection. Carry return connection size through the dirt pocket, making the reduction at the branch leading to the trap.
6. Install vacuum breakers on all applications to prevent retaining condensate in the coil. Connect the vacuum breaker between the coil inlet and the return main.
7. Do not drip supply mains through the coil.
8. Do not attempt to lift condensate when using modulating or ON/OFF control.
9. Size traps in accordance with manufacturers' recommendations. Be certain the required pressure differential will always be available. Do not undersize.
10. Use float and thermostatic or bucket traps with low pressure steam. On high pressure steam, use bucket traps. Use thermostatic traps only for air venting.
11. Use bucket traps only with ON/OFF control.
12. Locate traps at least 12 inches below the coil return connection.
13. Do not use modulating steam valves on high pressure systems.
14. Size modulating valves properly. Do not undersize.
15. Destiny steam coils are not recommended for freezing conditions or entering temperatures below 35°F (1.6°C).

Figure 17: Steam Coil Connections (Type SS)

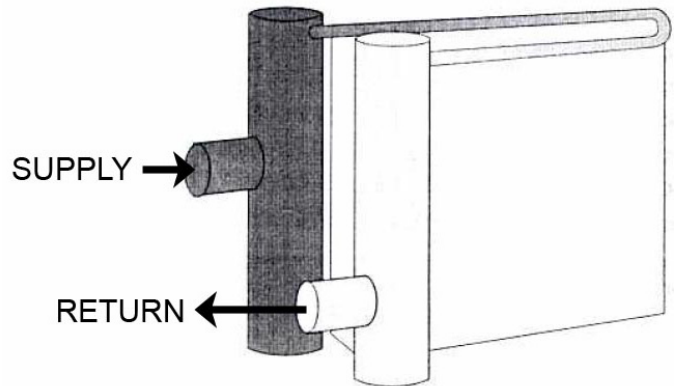

Water Heating Coils

Heating coil connection guidelines are listed below. Also, refer to [Figure 18](#) and [Figure 19](#).

1. Water supply and water return connections extend through the end panel of the coil section. All connections are labeled on the end panel.
2. Water supply and water return connections are copper sweat on units 002 through 010 and male NPT iron pipe on units 015 through 030.
3. When installing couplings, do not apply undue stress to the connection extending through unit panel. Use a backup pipe wrench to avoid breaking the weld between coil connection and header.
4. Follow recommendations of the control manufacturer regarding types, sizes, and installation of controls.
5. Hot water coils are not recommended for use with entering air below 40°F.
6. If fresh air and return air are to be heated by a hot water coil, take care in the design of the system to provide thorough mixing before air enters the coil.

Figure 18: Water Heating Coil Connections

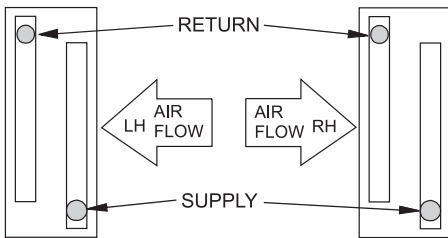

One and Two Row Coil with Spayed Headers

Figure 19: Piping Arrangements

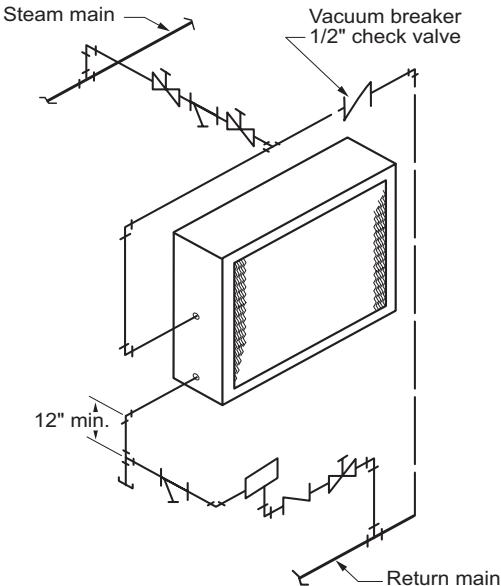

Drain Pan Traps

Destiny air handlers have a drain pan connection on both sides of the unit. Drain connections can be made on either side or both sides. Drain lines and traps should run full size from the drain pan connection. Drain pans should have traps to allow condensate from coils to drain freely. The trap depth and distance between the trap outlet and the drain pan outlet should be twice the static pressure in the drain pan section under normal operation for the trap to remain sealed. Refer to [Figure 20](#).

A secondary drain connection on the drain pan is standard on all Destiny units. Secondary drain connections are required in some applications as a visual means of identifying clogged primary drain lines.

Figure 20: Allow Adequate Distance Between Trap Outlet and Drain Outlet

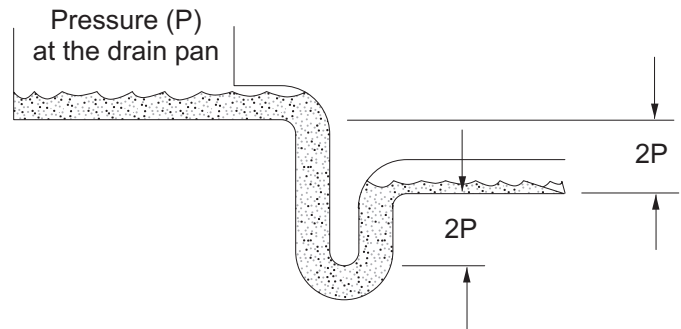

NOTE: The door panels on some applications have a close clearance over the drain pipes. Extend the drain fitting with a coupling if necessary for door clearance.

Internal Isolation Assembly Adjustment

Units have internally isolated fan and motor assemblies that are secured with brackets for shipment.

Before Operating the Unit

Remove the shipping bracket and bolts and discard. The shipping brackets located on the opposite drive side of the unit (Figure 21) are difficult to access from the drive side of the unit. Either remove them before the unit is assembled, or remove the panel on the opposite drive side to gain access.

Figure 21: Removing the Shipping Bracket, Sizes 002–010

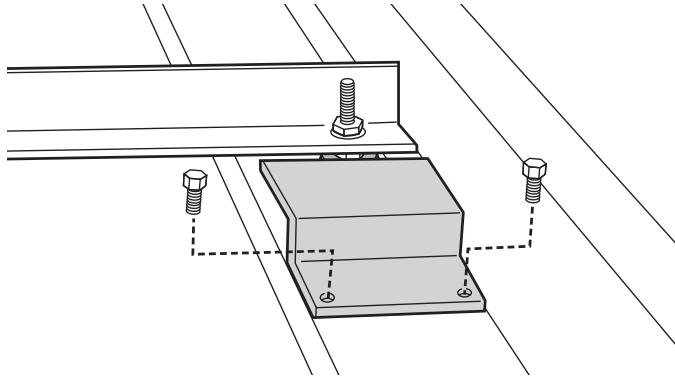

Spring Mount Adjustments—Twin Fan Units

The spring isolators under the four corners of the fan and motor assembly have been factory adjusted while the fan was not running. Refer to Table 1. With the unit operating at normal cfm and static pressure, the isolators should all be at the same height opening. If adjustments are required, loosen the 5/16" capscrew on top of the isolator and turn the adjusting bolt to lower or raise the fan and motor base. Retighten the capscrew when adjustments are completed. See Figure 22.

When seismic snubbers and/or thrust restraints are provided, no additional adjustments are required.

Table 1: Spring Mount Adjustment—Twin Fan Units

Spring mount adjustment at rest, unit sizes 015 to 030 ONLY			
Fan discharge position	Top or Bottom Horizontal "H"	Downblast "H"	Upblast "H"
1	3.75	3.75	4.25
2	4.25	3.75	4.25
3	4.25	3.75	4.25
4	3.75	3.75	4.25

Figure 22: Spring Mount Adjustments—Twin Fan Units

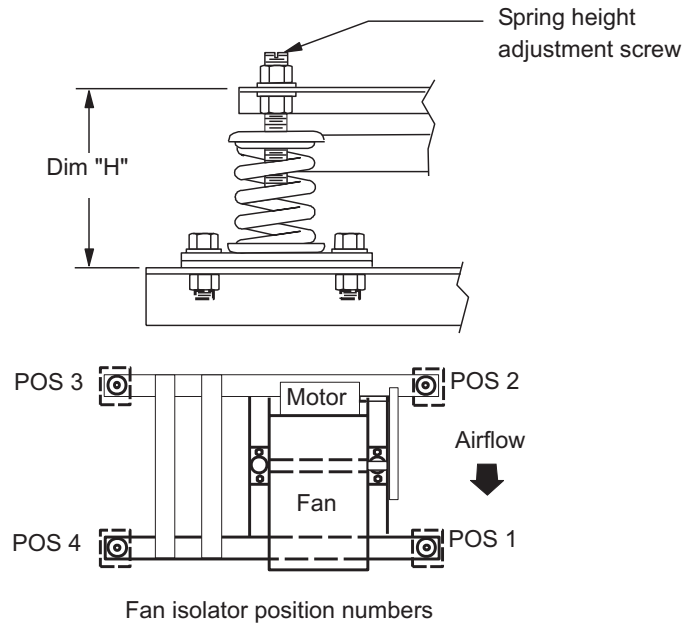

Electric Heat Section

(Optional)

Optional factory installed electric heat section consists of open coil duct heater mounted to the unit at the supply fan discharge. Heat section includes heating coils and an electrical control box with single point field power connection for heater and supply air fan.

Factory provided field knockouts are located on the side of the electric heat control panel for field power and control wiring to pass through. A factory installed non-fused disconnect is located in the electric heat control panel to disconnect power to the supply air fan and heater components. All wiring must be in conformance with the national electric code and local restrictions.

Open Coil Duct Heater

- Complete with overload and thermal protection
- Includes fan interlock and air flow switch safety protection
- High quality, alloy nichrome wire [80%Ni / 20%Cr]
- High di-electric level ceramic insulators
- Screw terminals

Single Point Power

- Non-fused disconnect
- Electric heat is factory wired including contactors and fuses per step and as required by UL. Refer to [Electric Heat Diagrams on page 23](#) for typical electric heat wiring diagrams
- Fan motor is factory wired including contactor or starter and fuses as applicable
- Fused control transformer allows the heater and fan to be sequenced by standard 24 volt thermostat
- Indoor control panel with tool access hinged door houses all components

Quality Control

- Heaters are di-electrically tested for 1000V plus twice the rated volts, or 2000V whichever is greater. The resistance of each heater is measured and recorded and must be within 5% of the rated value
- Every heater is checked during the production process and as a final assembly

Figure 23: Heater Nomenclature

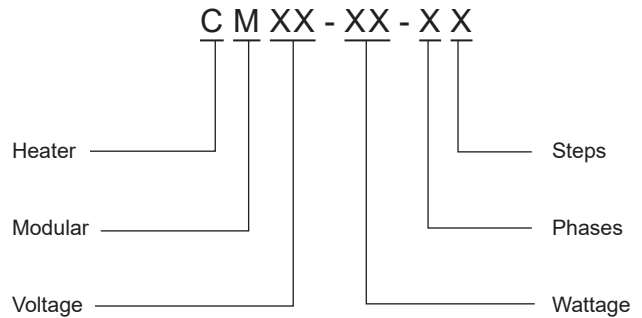
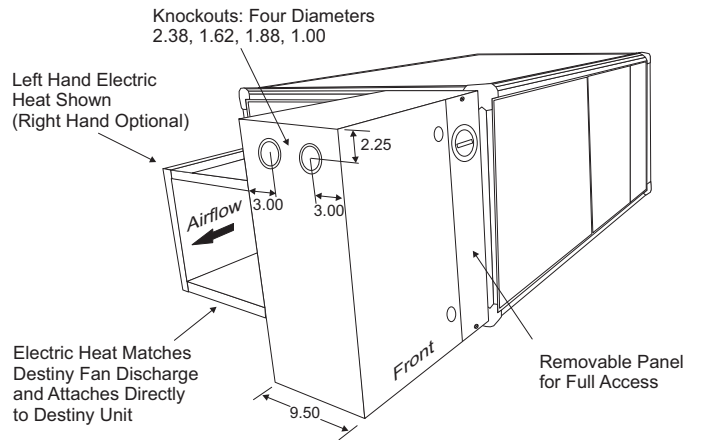

Figure 24: Destiny Unit with Left Hand Electric Heat



Electric Heat kW Options

Table 2: KW Options by Unit Size

KW Range	Unit Size					
	002	003	004	005	007	010
	1.5-10	2.5-20	2.5-20	4-26	6-38	6-55

Heater Amps

Table 3: Heater Amps

KW	Heater Amps				
	120V / 1Ø	240V / 1Ø	240V / 3Ø	480V / 3Ø	600V / 3Ø
1	8.33	4.17	2.41	1.20	0.96
1.5	12.50	6.25	3.61	1.81	1.45
2	16.67	8.33	4.82	2.41	1.93
2.5	20.83	10.42	6.02	3.01	2.41
3	25.00	12.50	7.23	3.61	2.89
3.5	29.17	14.58	8.43	4.21	3.37
4	33.33	16.67	9.63	4.82	3.85
4.5	37.50	18.75	10.84	5.42	4.34
5	41.67	20.83	12.04	6.02	4.82
5.5	45.83	22.92	13.25	6.62	5.30
6	50.00	25.00	14.45	7.23	5.78
6.5	54.17	27.08	15.66	7.83	6.26
7	58.33	29.17	16.86	8.43	6.74
7.5	62.50	31.25	18.06	9.03	7.23
8	66.67	33.33	19.27	9.63	7.71
8.5	70.83	35.42	20.47	10.24	8.19
9	75.00	37.50	21.68	10.84	8.67
10	83.33	41.67	24.08	12.04	9.63
11	91.67	45.83	26.49	13.25	10.60
12	100.00	50.00	28.90	14.45	11.56
13	108.33	54.17	31.31	15.66	12.52
14	116.67	58.33	33.72	16.86	13.49
15	125.00	62.50	36.13	18.06	14.45
16	133.33	66.67	38.54	19.27	15.41
17	141.67	70.83	40.94	20.47	16.38
18	150.00	75.00	43.35	21.68	17.34
19	158.33	79.17	45.76	22.88	18.30
20	N/A	83.33	48.17	24.08	19.27
22	N/A	91.67	52.99	26.49	21.19
24	N/A	100.00	57.80	28.90	23.12
26	N/A	108.33	62.62	31.31	25.05
28	N/A	116.67	67.44	33.72	26.97
30	N/A	125.00	72.25	36.13	28.90
32	N/A	133.33	77.07	38.54	30.83
34	N/A	141.67	81.89	40.94	32.76
36	N/A	150.00	86.71	43.35	34.68
38	N/A	158.33	91.52	45.76	36.61
40	N/A	N/A	96.34	48.17	38.54
45	N/A	N/A	108.38	54.19	43.35
50	N/A	N/A	120.42	60.21	48.17
55	N/A	N/A	132.47	66.23	52.99

Electric Heat Safety

Overcurrent Protection

Overcurrent fuse protection is provided for each stage of electric heat (in lieu of one per 48 amperes).

Thermal (Over Temperature) Protection

Primary - Automatic limit switches, one per step (120°F or 150°F as appropriate).

Backup - Manual reset thermal cutout (180°F).

Fan Interlock Method:

To prevent the heater from being energized unless the fan is on, the heater includes two interlock methods: an airflow switch, and the use of an auxiliary contact in the motor starter contactor (3ph) or a fan relay (1ph).

Airflow Switch:

The airflow switch provides the best means of protection against air failure caused by fan belt or other malfunction. Switches are of the differential pressure, diaphragm-operated type and require a minimum total pressure differential of .05" WC. The switch is factory wired in series with the manual reset cutout.

Minimum Air Velocity

Recommended minimum air flow through a specific heater is shown in [Table 4](#) through [Table 10](#).

Table 4: LAH002 Minimum Air Flow

Heater Capacity, kW	1.5	2	2.5	3	3.5	4	4.5	5	5.5	6	6.5	7	7.5	8	8.5
Minimum air flow, CFM	184	218	249	274	292	310	328	344	359	371	382	387	398	396	400
Heater Capacity, kW (cont.)	9	10													
Minimum air flow, CFM (cont.)	404	409													

Table 5: LAH003 Minimum Air Flow

Heater Capacity, kW	2.5	3	3.5	4	4.5	5	5.5	6	6.5	7	7.5	8	8.5	9	10
Minimum air flow, CFM	298	339	368	400	426	446	466	484	501	519	536	550	565	579	605
Heater Capacity, kW (cont.)	11	12	13	14	15	16	17	18	19	20					
Minimum air flow, CFM (cont.)	620	629	637	646	652	658	660	660	663	663					

Table 6: LAH004 Minimum Air Flow

Heater Capacity, kW	2.5	3	3.5	4	4.5	5	5.5	6	6.5	7	7.5	8	8.5	9	10
Minimum air flow, CFM	298	339	368	400	426	446	466	484	501	519	536	550	565	579	605
Heater Capacity, kW (cont.)	11	12	13	14	15	16	17	18	19	20					
Minimum air flow, CFM (cont.)	620	629	637	646	652	658	660	660	663	663					

Table 7: LAH005 Minimum Air Flow

Heater Capacity, kW	4	4.5	5	5.5	6	6.5	7	7.5	8	8.5	9	10	11	12	13
Minimum air flow, CFM	447	477	511	538	561	584	603	622	641	656	672	706	740	771	794
Heater Capacity, kW (cont.)	14	15	16	17	18	19	20	22	24	26					
Minimum air flow, CFM (cont.)	809	824	832	840	847	855	859	866	870	874					

Table 8: LAH005 Minimum Air Flow

Heater Capacity, kW	4	4.5	5	5.5	6	6.5	7	7.5	8	8.5	9	10	11	12	13
Minimum air flow, CFM	447	477	511	538	561	584	603	622	641	656	672	706	740	771	794
Heater Capacity, kW (cont.)	14	15	16	17	18	19	20	22	24	26					
Minimum air flow, CFM (cont.)	809	824	832	840	847	855	859	866	870	874					

Table 9: LAH007 Minimum Air Flow

Heater Capacity, kW	6	6.5	7	7.5	8	8.5	9	10	11	12	13	14	15	16	17
Minimum air flow, CFM	637	673	704	729	750	765	790	831	867	903	938	969	1000	1030	1056
Heater Capacity, kW (cont.)	18	19	20	22	24	26	28	30	32	34	36	38			
Minimum air flow, CFM (cont.)	1076	1096	1102	1117	1132	1142	1153	1163	1168	1168	1173	1173			

Table 10: LAH010 Minimum Air Flow

Heater Capacity, kW	6	6.5	7	7.5	8	8.5	9	10	11	12	13	14	15	16	17
Minimum air flow, CFM	637	673	704	729	750	765	790	831	867	903	938	969	1000	1030	1056
Heater Capacity, kW (cont.)	18	19	20	22	24	26	28	30	32	34	36	38	40	45	
Minimum air flow, CFM (cont.)	1076	1096	1102	1117	1132	1142	1153	1163	1168	1168	1173	1173	1173	1178	

Electric Heat Operation

⚠ CAUTION

Heaters are furnished for zero clearance between the duct and combustible surfaces. However, it is not recommended that any combustible material be allowed to touch any electric duct heater or immediate surrounding areas.

⚠ CAUTION

Heaters are not intended to be installed with less than 20" of straight duct at the outlet of the heater.

ⓘ NOTICE

Field wiring necessary temperatures are:

- 1) 194°F for dry weather.
- 2) 167°F for humid weather.

The sampling probe is suitable for left-hand or right-hand airflow and in positive pressure applications may require field adjustment so the probe faces upstream. This is normally done during installation by removing two screws, rotating the probe 180° and replacing the screws. Removing the heater from the duct is not necessary.

The electric heater is designed to operate while installed and connected to the unit at the supply air fan discharge, to heat air passing through the heating elements.

Temperature rise is very important and can be obtained using the following calculation:

$$\text{Temperature Rise} = (KW) \times (3159) / CFM$$

NOTE: Maximum leaving air temperature = 120°F

Field Power Wiring

DANGER

Improper ground may result in severe injury or death.
Check grounding nut tightness before connecting power to the external junction box.

DANGER

Hazardous voltage. Can cause severe injury or death.
Disconnect electric power before servicing equipment. More than one disconnect may be required to de-energize the unit.

Wiring must comply with all applicable codes and ordinances. The warranty is voided if wiring is not in accordance with these specifications. An open fuse or starter indicates a short, ground, or overload. Before replacing a fuse or resetting a starter, identify the trouble and correct.

According to the [National Electrical Code](#), a disconnecting means shall be located within sight of and readily accessible from the air conditioning equipment. Power leads must be over-current protected at the point of distribution. The maximum allowable overcurrent protection (MROPD) appears on the unit nameplate.

Supply Power Wiring

1. Allowable voltage tolerances:
 - a. 60 Hertz
 - Nameplate 208V: Min. 187V, Max. 229V
 - Nameplate 230V: Min. 207V, Max. 253V
 - Nameplate 460V: Min. 414V, Max. 506V
 - Nameplate 575V: Min. 518V, Max. 633V
 - b. 50 Hertz
 - Nameplate 380V: Min. 360V, Max. 418V
2. Minimum Circuit Ampacity (MCA) Calculation is based on the following formulas:
 - Electric heat less than or equal to 50 kW
 $MCA = 1.25 (\text{heater FLA} + \text{largest motor loads}) + (\text{the rest of the loads})$
 - Electric heat greater than or equal to 50 kW
 $MCA = 1.25 (\text{largest motor load}) + (\text{the rest of the loads}) + \text{heater FLA}$
3. Size wires in accordance with Table 310-16 or 310-19 of the National Electrical Code.
4. MROPD is calculated per UL 1995 methodology.
5. Wires should be sized for a maximum of 3% voltage drop.

Electrical Installation

1. Electrical service to the fan must correspond to the rated voltage on the motor nameplate and be in conformance with the [National Electric Code](#) and local restrictions.
2. The fan section metal frame must be connected to the building electrical ground.
3. A door electrical interlock is not provided as standard
4. Thermal motor protection is external to the unit. Unless the unit is provided with a unit mounted starter, thermal protection and a disconnect switch provision per electric codes are provided by others.
5. When the unit is factory provided with a junction box, disconnect switch, starter, or a variable frequency drive (VFD), the components are mounted on the outside of the unit cabinet. Factory wiring is provided from the device to the unit internal motor.

Variable Frequency Drive (VFD)

(Optional)

⚠ DANGER

Fire hazard. Failure to use fast-blow J-type fuses could result in property damage, injury, or death. Fast-blow fuses must be installed upstream of a VFD.

⚠ CAUTION

Never operate a fan over the maximum speed indicated on the fan curve, as this may cause fan damage and severe unit vibration.

1. When the unit is provided with a VFD only, refer to the VFD manual for wire size and torque requirements. A fast-blow fused disconnect is recommended for VFD applications. Motor operation below 20 Hz or over 90 Hz is not recommended. For typical wiring diagrams, see [Figure 29](#) and [Figure 30](#).
2. Refer to [IM 1190](#) (MD4 drives) or [IM 1191](#) (MD5 drives) for VFD set-up details. The drives are installed with only default programming and are to be field configured to meet application requirements.
3. Units with Direct-Drive Plenum fans need to be reprogrammed in the field according to design point parameters. Refer to project documentation and/or fan curves ([Figure 33](#) through [Figure 41](#)) for appropriate fan speeds associated with the job. Use the formula below to calculate the maximum frequency associated with the maximum allowable fan speed.

$$F_{max} = 60 \text{ Hz} \times (W_{max} / W_{motor})$$

F_{max} - maximum frequency allowable for particular application (Hz)

W_{max} - maximum fan speed (rpm); refer to fan curves

W_{motor} - nominal motor speed (1800/3600 rpm); refer to motor nameplate

Refer to [Table 34 on page 45](#) for operating limit information for Backward-Inclined Direct-Drive Plenum fans.

Starters and Disconnects

(Optional)

1. The fan motor is factory wired to an externally mounted control box. Control box options include: disconnect-only (fused and non-fused) and starter-fused disconnect transformer.
2. A fast-blow fused disconnect (J-type fuses) is used in VFD applications.
3. A fused control transformer allows the fan to be sequenced by standard 24-volt thermostat or controller.
4. An indoor panel with tool access hinged door houses all the components and is generally mounted on the unit's bulkhead panel. The panel enclosure has several knockouts located on the side, top, and bottom.
5. All field wiring must be in conformance with the National Electric Code and local restrictions.
6. Refer to [Figure 27](#) and [Figure 28](#) for typical disconnect-only wiring diagrams. Refer to [Figure 46](#) and [Figure 47](#) for typical full control box diagrams.

Electric Heat Diagrams

Figure 25: Typical 1-Phase, 240 Volt Electric Heat Wiring Diagram

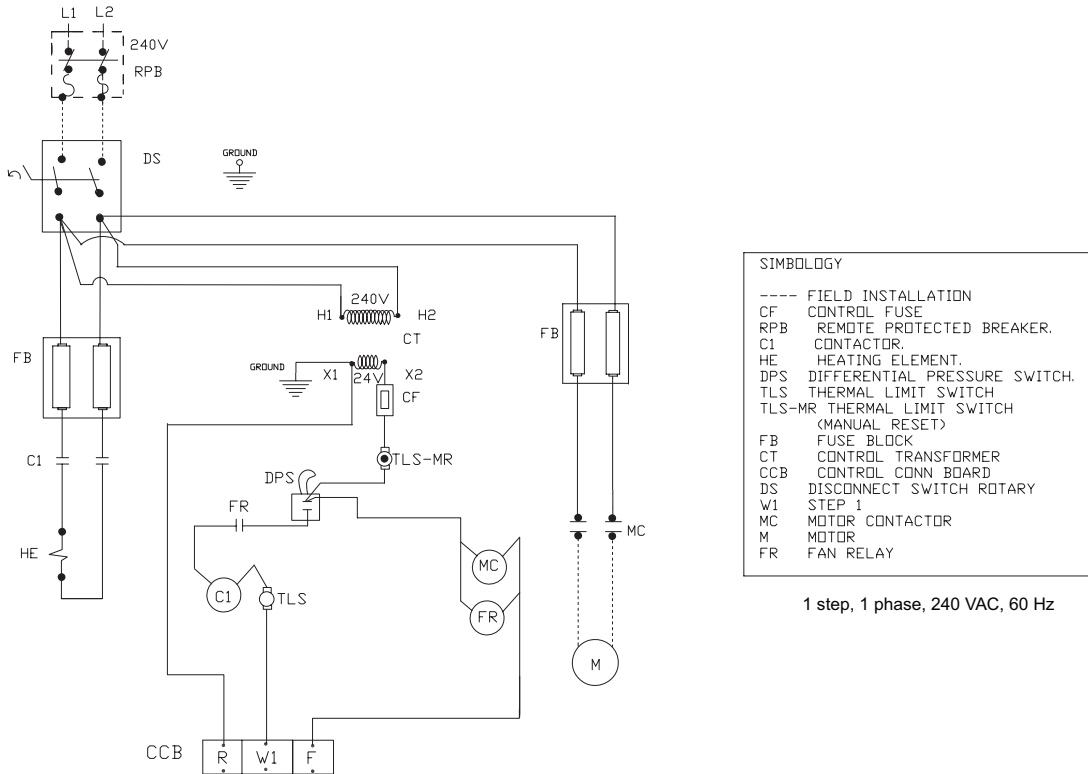
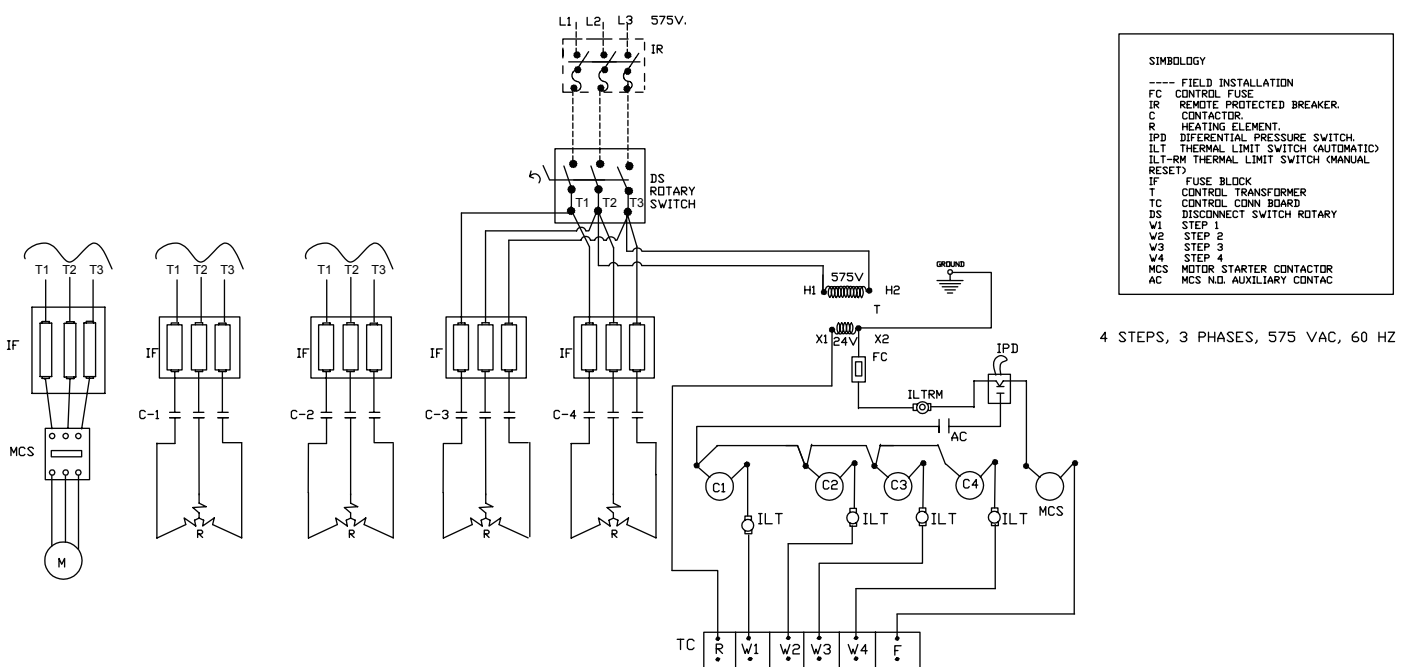

Figure 26: Typical 3-Phase, 575 Volt Electric Heat Wiring Diagram



Disconnect-Only Diagrams

Figure 27: Typical Single-Phase, Disconnect-Only Wiring Diagram

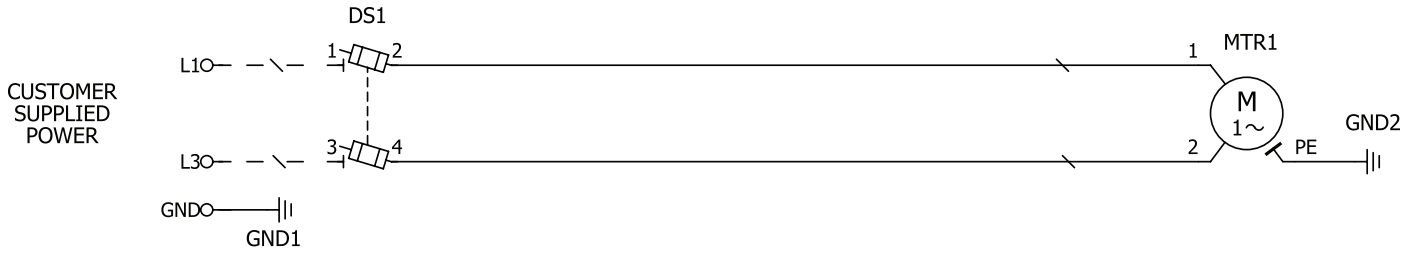
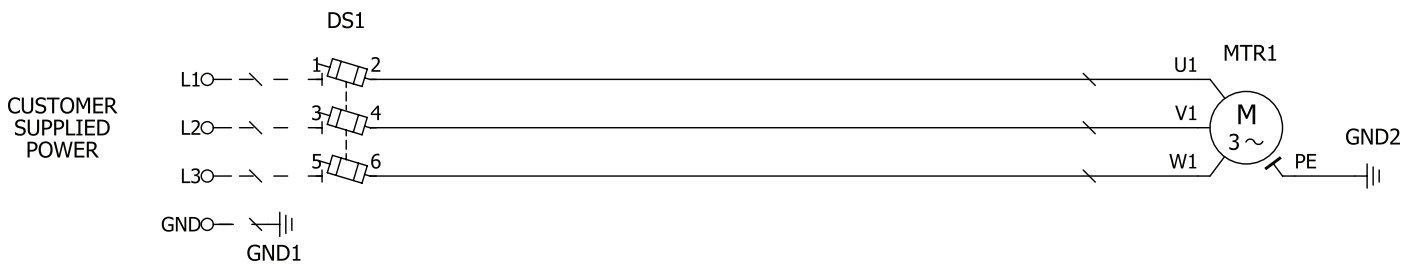

Figure 28: Typical 3-Phase, Disconnect-Only Wiring Diagram



VFD Diagrams

Figure 29: Typical MD4 VFD Wiring Diagram

208VAC, 3 PHASE, 60Hz

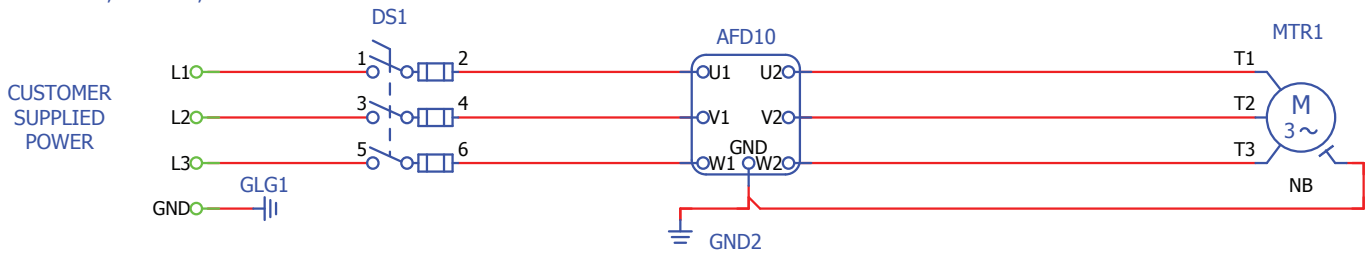

Note: Fused disconnect DS1 is optional

Figure 30: Typical MD5 VFD Wiring Diagram

575VAC, 3 PHASE, 60Hz

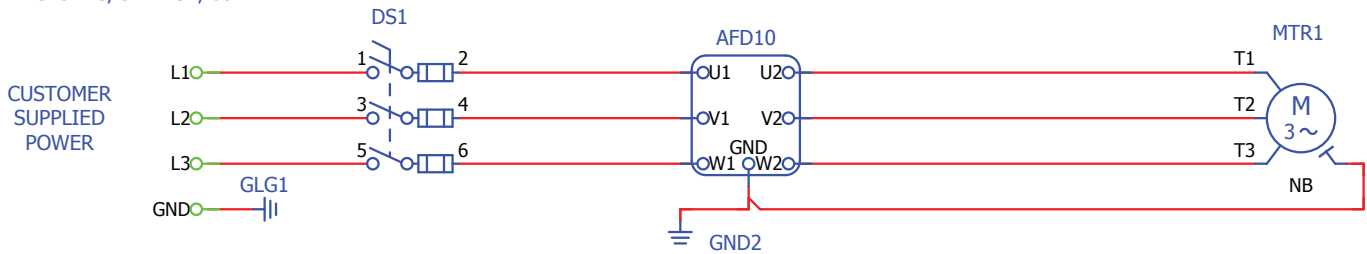

Note: Fused disconnect DS1 is optional

Figure 31: Typical Single-Phase Starter/Disconnect Wiring Diagram

208V, Single Phase, 60Hz

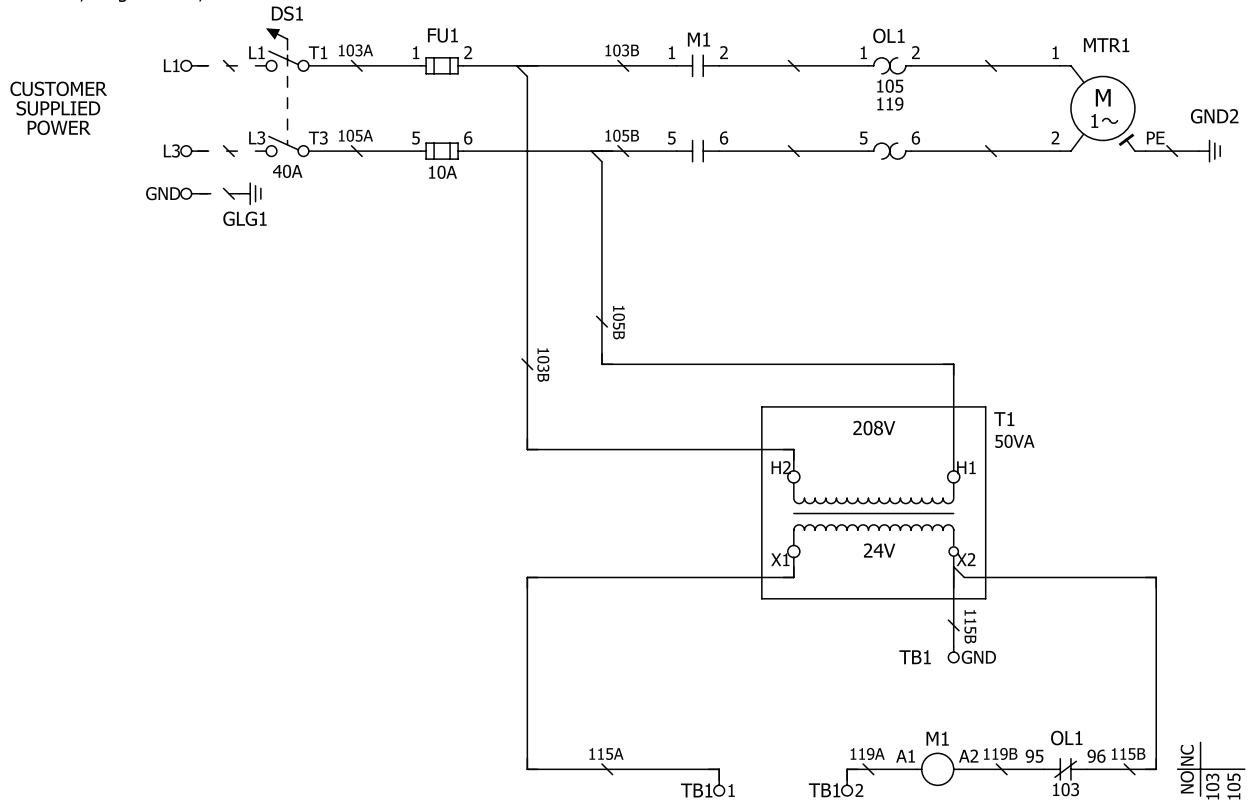
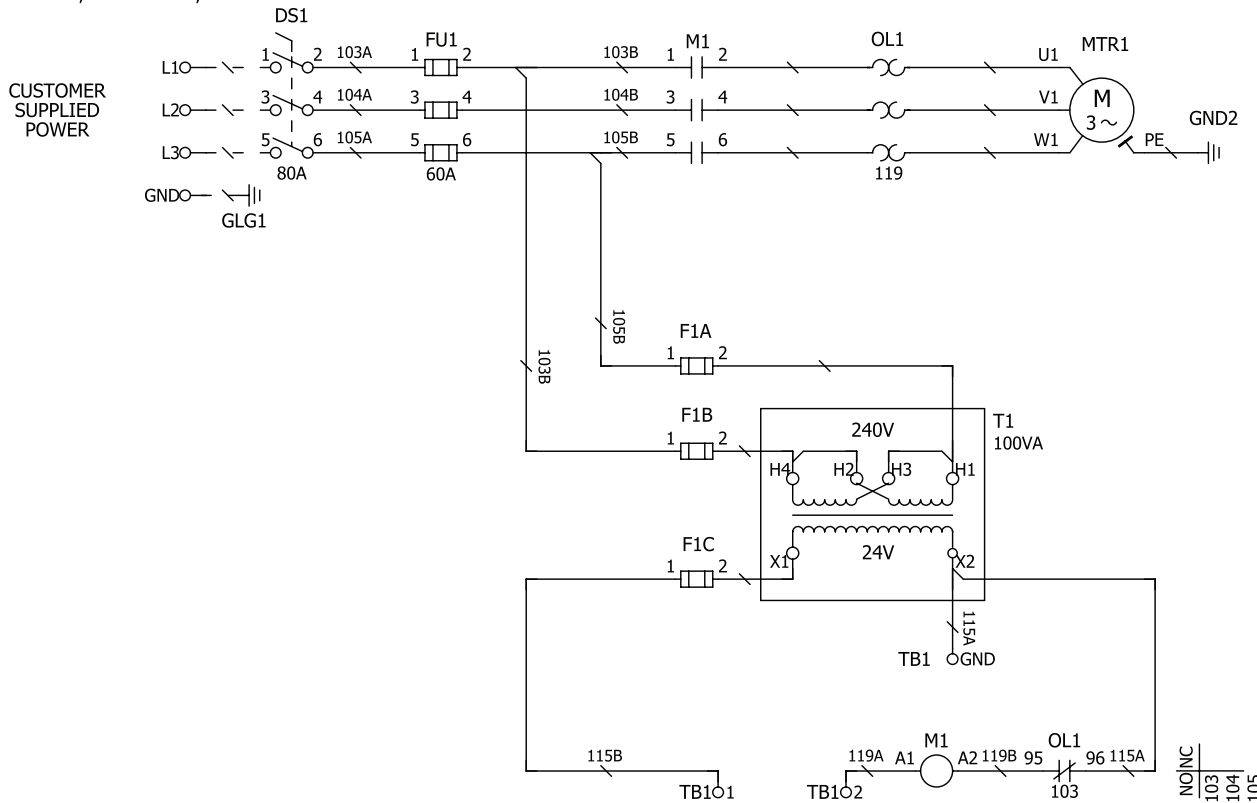

Figure 32: Typical 3-Phase Starter/Disconnect Wiring Diagram

230V, Three Phase, 60Hz



Component and Section Weights

Table 11: Unit Coil Weights

Coil type	Weight—lbs (kg)									
	002	003	004	005	007	010	015	020	025	030
4-row chilled water	31.64 (14.35)	40.56 (18.40)	54.30 (24.64)	59.19 (26.85)	84.80 (38.46)	111.99 (50.80)	185.93 (84.34)	255.08 (115.70)	298.34 (135.32)	341.54 (154.92)
6-row chilled water	39.94 (18.12)	54.81 (24.86)	69.01 (31.30)	86.91 (39.42)	112.30 (50.94)	154.05 (69.88)	261.55 (118.64)	353.14 (160.18)	416.35 (188.85)	477.93 (216.79)
1-row hot water	16.11 (7.31)	19.95 (9.05)	28.36 (12.86)	33.60 (15.24)	45.86 (20.80)	66.07 (29.97)	91.35 (41.44)	116.29 (52.75)	132.03 (59.89)	168.86 (76.59)
2-row hot water	24.36 (11.05)	29.96 (13.59)	38.07 (17.27)	46.13 (20.92)	64.28 (29.16)	83.91 (38.06)	121.10 (54.93)	171.48 (77.78)	197.12 (89.41)	223.03 (101.16)
4-row DX	32.73 (14.85)	42.91 (19.46)	50.11 (22.73)	64.80 (29.39)	88.18 (40.00)	115.42 (52.35)	195.54 (88.70)	248.63 (112.78)	300.8 (136.44)	344.86 (156.43)
6-row DX	43.37 (19.67)	57.01 (25.86)	71.53 (32.45)	91.69 (41.59)	105.18 (47.71)	158.52 (71.90)	268.37 (121.73)	365.31 (165.71)	429.85 (194.98)	493.24 (223.73)

Table 12: Base Unit Cabinet Weights—Horizontal Unit with Forward Curved Fan

Unit size	Weight—lbs (kg)									
	Configuration		Configuration		Configuration		Configuration		Configuration	
	No heat	Reheat coil	No heat	Reheat coil	No heat*	Reheat coil	No heat*	Reheat coil	Preheat coil	
	Flat filters	Flat filters	Angular filters	Angular filters	Flat filters	Flat filters	Angular filters	Angular filters	Flat filters	Angular filters
	Cooling coil	Cooling coil	Cooling coil	Cooling coil	N/A	N/A	N/A	N/A	Cooling coil	Cooling coil
Fan	Fan	Fan	Fan	Fan	Fan	Fan	Fan	Fan	Fan	
002	142.34 (64.56)		187.56 (85.08)		122.36 (55.50)		149.39 (67.76)		157.12 (71.27)	184.19 (83.55)
003	170.89 (77.51)		213.02 (96.62)		148.04 (67.15)		169.18 (76.74)		186.67 (84.67)	208.34 (94.50)
004	207.68 (94.20)		257.99 (117.02)		182.04 (82.47)		205.76 (93.33)		233.73 (106.02)	257.55 (116.82)
005	245.41 (111.32)		317.41 (143.98)		213.25 (96.73)		253.09 (114.80)		267.13 (121.17)	307.89 (139.66)
007	262.71 (119.16)		340.86 (154.61)		224.74 (101.94)		271.81 (123.29)		298.53 (135.41)	346.93 (157.36)
010	302.58 (137.25)		392.63 (178.09)		260.15 (118.00)		312.73 (141.85)		341.67 (154.98)	395.58 (179.43)
015	359.18 (162.92)		463.09 (210.05)		352.58 (159.93)		411.89 (186.83)		419.72 (190.38)	480.74 (218.06)
020	445.55 (202.10)		596.73 (270.67)		440.70 (199.90)		533.01 (241.77)		511.86 (232.18)	606.56 (275.13)
025	559.02 (253.57)		736.09 (333.89)		554.95 (251.72)		658.10 (298.51)		616.52 (279.65)	773.96 (351.06)
030	603.25 (273.63)		817.52 (370.82)		599.00 (271.70)		730.10 (331.17)		633.19 (287.21)	830.10 (376.53)

NOTE: *Ventilation only

Table 13: Base Unit Cabinet Weights—Horizontal Unit with Plenum Fan

Unit size	Weight—lbs (kg)									
	Configuration		Configuration		Configuration		Configuration		Configuration	
	No heat	Reheat coil	No heat	Reheat coil	No heat*	Reheat coil	No heat*	Reheat coil	Preheat coil	Angular filters
	Flat filters	Flat filters	Angular filters	Angular filters	Flat filters	Flat filters	Angular filters	Angular filters	Flat filters	Angular filters
	Cooling coil	Cooling coil	Cooling coil	Cooling coil	N/A	N/A	N/A	N/A	Cooling coil	Cooling coil
Fan	Fan	Fan	Fan	Fan	Fan	Fan	Fan	Fan	Fan	
002	126 (57)		125 (57)		102 (46)		105 (47)		129 (59)	128 (58)
003	140 (63)		161 (73)		131 (59)		151 (69)		168 (76)	173 (78)
004	220 (100)		214 (97)		193 (88)		193 (88)		225 (102)	252 (114)
005	186 (84)		231 (105)		175 (79)		202 (92)		216 (98)	237 (107)
007	285 (129)		315 (143)		224 (102)		267 (121)		304 (138)	349 (158)
010	309 (140)		395 (179)		270 (122)		316 (143)		392 (178)	454 (206)
015	561 (254)		600 (272)		545 (247)		583 (264)		626 (284)	674 (306)
020	663 (301)		708 (321)		679 (308)		692 (314)		729 (331)	774 (351)
025	743 (337)		740 (335)		698 (317)		845 (383)		767 (348)	788 (357)
030	770 (349)		947 (430)		749 (340)		894 (406)		929 (421)	941 (427)

NOTE: *Ventilation only

Table 14: Base Unit Cabinet Weights—Vertical Unit

Unit size	Weight—lbs (kg)			
	Configuration		Configuration	
	No heat	Reheat coil	No heat*	Reheat coil
	Flat filters	Flat filters	Flat filters	Flat filters
	Cooling coil	Cooling coil	N/A	N/A
	Fan	Fan	Fan	Fan
002	134.70 (61.10)		134.70 (61.10)	
003	183.20 (83.10)		183.20 (83.10)	
004	209.79 (95.16)		209.79 (95.16)	
005	239.00 (108.40)		239.00 (108.40)	
007	349.08 (158.30)		349.08 (158.30)	
010	399.23 (181.09)		399.23 (181.09)	
015	484.20 (219.63)		484.20 (219.63)	
020	566.96 (257.17)		566.96 (257.17)	
025	725.28 (328.98)		725.28 (328.98)	
030	750.14 (340.26)		750.14 (340.26)	

Note: *Ventilation only

Table 15: Electric Heat Weights

Unit size	Weight—lbs (kg)			
	1 Step	2 Steps	3 Steps	4 Steps
002	31 (14.00)	35 (16.00)	—	—
003	32 (14.50)	36 (16.50)	41 (18.50)	45 (20.50)
004	32 (14.50)	36 (16.50)	41 (18.50)	45 (20.50)
005	34 (15.50)	39 (17.50)	43 (19.50)	47 (21.50)
007	36 (16.50)	41 (18.50)	45 (20.50)	50 (22.50)
010	36 (16.50)	41 (18.50)	45 (20.50)	50 (22.50)

Table 16: Motor Weights***

Unit size	Motor	Fan motor size – horsepower (hp)											
		0.33	0.5	0.75	1	1.5	2	3	5	7.5	10	15	20
002	Max. weight, lb (kg)	25 (11.33)	27 (12.25)	27 (12.25)	40 (18.41)	44 (19.96)	46 (20.87)	—	—	—	—	—	—
	Frame size	56	56	56	*	**	145T	—	—	—	—	—	—
	Shaft dia., in	5/8	5/8	5/8	*	**	7/8	—	—	—	—	—	—
003	Max. weight, lb (kg)	25 (11.33)	27 (12.25)	27 (12.25)	40 (18.41)	44 (19.96)	46 (20.87)	69 (31.30)	85 (38.55)	—	—	—	—
	Frame size	56	56	56	*	**	145T	182T	184T	—	—	—	—
	Shaft dia., in	5/8	5/8	5/8	*	**	7/8	1-1/8	1-1/8	—	—	—	—
004	Max. weight, lb (kg)	25 (11.33)	27 (12.25)	27 (12.25)	40 (18.41)	44 (19.96)	46 (20.87)	69 (31.30)	85 (38.55)	—	—	—	—
	Frame size	56	56	56	*	**	145T	182T	184T	—	—	—	—
	Shaft dia., in	5/8	5/8	5/8	*	**	7/8	1-1/8	1-1/8	—	—	—	—
005	Max. weight, lb (kg)	—	—	27 (12.25)	40 (18.41)	44 (19.96)	46 (20.87)	69 (31.30)	85 (38.55)	—	—	—	—
	Frame size	—	—	56	*	**	145T	182T	184T	—	—	—	—
	Shaft dia., in	—	—	5/8	*	**	7/8	1-1/8	1-1/8	—	—	—	—
007	Max. weight, lb (kg)	—	—	—	40 (18.41)	44 (19.96)	46 (20.87)	69 (31.30)	85 (38.55)	129 (58.51)	—	—	—
	Frame size	—	—	—	*	**	145T	182T	184T	213T	—	—	—
	Shaft dia., in	—	—	—	*	**	7/8	1-1/8	1-1/8	1-3/8	—	—	—
010	Max. weight, lb (kg)	—	—	—	40 (18.41)	44 (19.96)	46 (20.87)	69 (31.30)	85 (38.55)	129 (58.51)	—	—	—
	Frame size	—	—	—	*	**	145T	182T	184T	213T	—	—	—
	Shaft dia., in	—	—	—	*	**	7/8	1-1/8	1-1/8	1-3/8	—	—	—
015	Max. weight, lb (kg)	—	—	—	—	44 (19.96)	46 (20.87)	69 (31.30)	85 (38.55)	129 (58.51)	129 (58.51)	217 (98.43)	—
	Frame size	—	—	—	—	143T	145T	182T	184T	213T	215T	254T	—
	Shaft dia., in	—	—	—	—	7/8	7/8	1-1/8	1-1/8	1-3/8	1-3/8	1-5/8	—
020	Max. weight, lb (kg)	—	—	—	—	—	46 (20.87)	69 (31.30)	85 (38.55)	129 (58.51)	129 (58.51)	217 (98.43)	—
	Frame size	—	—	—	—	—	145T	182T	184T	213T	215T	254T	—
	Shaft dia., in	—	—	—	—	—	7/8	1-1/8	1-1/8	1-3/8	1-3/8	1-5/8	—
025	Max. weight, lb (kg)	—	—	—	—	—	—	—	85 (38.55)	129 (58.51)	129 (58.51)	217 (98.43)	259 (117.48)
	Frame size	—	—	—	—	—	—	—	184T	213T	215T	254T	256T
	Shaft dia., in	—	—	—	—	—	—	—	1-1/8	1-3/8	1-3/8	1-5/8	1-5/8
030	Max. weight, lb (kg)	—	—	—	—	—	—	—	85 (38.55)	129 (58.51)	129 (58.51)	217 (98.43)	259 (117.48)
	Frame size	—	—	—	—	—	—	—	184T	213T	215T	254T	256T
	Shaft dia., in	—	—	—	—	—	—	—	1-1/8	1-3/8	1-3/8	1-5/8	1-5/8

NOTE:
 * 56/56H frame and 5/8" shaft diameter for 1-ph motors. 143T frame and 7/8" shaft diameter for 3-ph motors
 ** 56/56H frame and 5/8" shaft diameter for 1-ph motors. 143T frame and 7/8" shaft diameter for 3-ph motors
 *** Refer to "HP range" in [Table 17](#) and [Table 18 on page 30](#) for applicable motors per unit size

Fan Data

Table 17: Forward Curved Fan Data

	Unit size									
	002	003	004	005	007	010	015	020	025	030
Fan type	DWDI FC	DWDI FC	DWDI FC	DWDI FC	DWDI FC	DWDI FC	Twin DWDI FC	Twin DWDI FC	Twin DWDI FC	Twin DWDI FC
Diameter	7/7	9/9	9/9	10/10	12/12	12/12	10/10	12/12	15/15	15/15
HP range	0.50–2	0.50–3	0.5–5	0.75–5	1–5	1–7.5	2–15	3–15	5–20	5–20
cfm minimum fan limit	206	206	529	529	765	765	1059	1529	2118	2118
cfm maximum fan limit	2,088	2,088	5,765	6,176	8,529	8,529	12,353	17,059	26,706	26,706
Maximum rpm	2,680	2,650	2,650	2,100	1,700	1,700	2,100	1,700	1,500	1,500
Class	1	1	1	1	1	1	1	1	1	1
Motor sheave	VP, VL, VM	VP, VL, VM	VP, VL, VM	VP, VL, VM	VP, VL, VM	VP, VL, VM	VP, VL, VM	VP, VL, VM	VP, VL, VM	VP, VL, VM
Fan sheave	AK, BK	AK, BK	AK, BK	AK, BK	AK, BK	AK, BK	AK, BK	AK, BK	AK, BK	AK, BK
Belt	A, AX, B, BX	A, AX, B, BX	A, AX, B, BX	A, AX, B, BX	A, AX, B, BX	A, AX, B, BX	A, AX, B, BX	A, AX, B, BX	A, AX, B, BX	A, AX, B, BX
Fan shaft diameter	3/4"	3/4"	3/4"	3/4"	1.0"	1.0"	3/4"	1.0"	1.0"	1.0"
Weight—lbs (kg)	19.03 (8.63)	33.95 (15.40)	33.95 (15.40)	41.45 (18.80)	60.85 (27.60)	60.85 (27.60)	79.37 (36.00)	126.77 (57.50)	154.87 (70.25)	154.87 (70.25)

Table 18: Plenum Fan Data

	Unit size									
	002	003	004	005	007	010	015	020	025	030
Fan type	SWSI DD Plenum	SWSI DD Plenum	SWSI DD Plenum	SWSI DD Plenum	SWSI DD Plenum	SWSI DD Plenum	SWSI DD Plenum	SWSI DD Plenum	SWSI DD Plenum	SWSI DD Plenum
Diameter (in)	9	10	11	12.5	14	16	20	22	25	25
HP range	1.5–2	1.5–5	1–5	1–5	1–7.5	1–7.5	1.5–15	2–15	5–20	5–20
cfm minimum fan limit	100	150	200	200	250	325	525	650	800	800
cfm maximum fan limit	1800	2650	4100	4100	5000	5200	9200	12,900	16,150	16,150
Maximum rpm	5175	5175	4245	4245	3600	2625	2265	2310	2060	2060
Weight with smallest motor—lbs (kg)	50 (22.7)	57 (25.9)	59 (26.8)	62 (28.1)	71 (32.2)	86 (39)	147 (66.7)	176 (79.8)	263 (119.3)	263 (119.3)
Weight with largest motor—lbs (kg)	56 (25.4)	84 (38.1)	86 (39)	89 (40.4)	114 (51.7)	154 (69.9)	281 (127.4)	312 (141.5)	363 (164.7)	363 (164.7)

Filter Data

Table 19: Filter Data

	Unit size									
	002	003	004	005	007	010	015	020	025	030
Flat filters										
Flat filter bank number	1	1	1	1	1	1	2	2	2	2
Flat filter (qty) size	(1) 16 × 25	(1) 18 × 24	(2) 16 × 20	(2) 20 × 24	(2) 24 × 24	(3) 20 × 25	(3) 12 × 24 (3) 24 × 24	(6) 24 × 24	(4) 20 × 24 (4) 24 × 24	(6) 16 × 25 (4) 20 × 25
Flat filter depth options	2", 4"	2", 4"	2", 4"	2", 4"	2", 4"	2", 4"	2", 4"	2", 4"	2", 4"	2", 4"
Angular filters										
Angular filter bank number	1	1	1	2	2	2	2	3	3	3
Angular filter (qty) size	(1) 20 × 24	(2) 16 × 20	(2) 20 × 20	(4) 16 × 20	(4) 16 × 25	(6) 16 × 20	(6) 20 × 24	(9) 20 × 24	(6) 20 × 24 (6) 24 × 24	(6) 20 × 24 (6) 24 × 24
Angular filter depth options	2"	2"	2"	2"	2"	2"	2"	2"	2"	2"

Coil Data

Table 20: Coil Data—Chilled Water

	Unit size									
	002	003	004	005	007	010	015	020	025	030
Fin height	14	16	16	22	22	26	32.5	45	45	52.5
Fin length	21	27	34	34	48	54	65	65	80	80
Rows	4, 6	4, 6	4, 6	4, 6	4, 6	4, 6	4, 6	4, 6	4, 6	4, 6
FPI	12	12	12	12	12	12	12	12	12	12
Connection material	Copper sweat	Copper sweat	Copper sweat	Copper sweat	Copper sweat	Copper sweat	Steel NPT	Steel NPT	Steel NPT	Steel NPT
Connection size 4-row	0.875 OD	1.125 OD	1.625 OD	1.625 OD	1.625 OD	1.625 OD	1.5 NPT	2.5 NPT	2.5 NPT	2.5 NPT
Connection size 6-row	0.875 OD	1.125 OD	1.625 OD	1.625 OD	1.625 OD	2.125 OD	2.0 NPT	2.5 NPT	2.5 NPT	2.5 NPT
Casing	Galv./SS	Galv./SS	Galv./SS	Galv./SS	Galv./SS	Galv./SS	Galv./SS	Galv./SS	Galv./SS	Galv./SS

Table 21: Coil Data—DX Coils

	Unit size									
	002	003	004	005	007	010	015	020	025	030
Fin height	14	16	16	22	22	26	32.5	45	45	52.5
Fin length	21	27	34	34	48	54	65	65	80	80
Rows	4, 6	4, 6	4, 6	4, 6	4, 6	4, 6	4, 6	4, 6	4, 6	4, 6
FPI	12	12	12	12	12	12	12	12	12	12
Connection material	Copper sweat	Copper sweat	Copper sweat	Copper sweat	Copper sweat	Copper sweat	Copper sweat	Copper sweat	Copper sweat	Copper sweat
Suction Connection size 4-row	0.875 OD	1.125 OD	1.125 OD	1.125 OD	1.625 OD	1.625 OD	1.625 OD	1.625 OD	1.625 OD	1.625 OD
Liquid Connection size 4-row	0.625 OD	0.625 OD	0.625 OD	0.625 OD	0.875 OD	0.875 OD	1.125 OD	0.625 OD	0.875 OD	1.125 OD
Suction Connection size 6-row	0.875 OD	1.125 OD	1.625 OD	1.625 OD	1.625 OD	2.125 OD	1.625 OD	1.625 OD	2.125 OD	2.625 OD
Liquid Connection size 6-row	0.625 OD	0.625 OD	0.625 OD	1.125 OD	1.125 OD	1.125 OD	0.875 OD	0.875 OD	1.125 OD	1.375 OD
Casing	Galv./SS	Galv./SS	Galv./SS	Galv./SS	Galv./SS	Galv./SS	Galv./SS	Galv./SS	Galv./SS	Galv./SS
Number of circuits	1	1	1	1	1	1	2	2	2	2
Circuit type	Normal	Normal	Normal	Normal	Normal	Normal	Face split	Face split	Face split	Face split

Table 22: Coil Data—Hot Water Coils

	Unit size									
	002	003	004	005	007	010	015	020	025	030
Fin height	14	16	16	22	22	26	32.5	45	45	52.5
Fin length	21	27	34	34	48	54	65	65	80	80
Rows	1, 2	1, 2	1, 2	1, 2	1, 2	1, 2	1, 2	1, 2	1, 2	1, 2
FPI	12	12	12	12	12	12	12	12	12	12
Connection material	Copper sweat	Copper sweat	Copper sweat	Copper sweat	Copper sweat	Copper sweat	Steel NPT	Steel NPT	Steel NPT	Steel NPT
Connection size 1-row	0.625 OD	0.625 OD	0.875 OD	0.875 OD	1.125 OD	1.375 OD	1.0 NPT	1.5 NPT	1.5 NPT	2.0 NPT
Connection size 2-row	0.875 OD	0.875 OD	1.125 OD	1.125 OD	1.625 OD	1.625 OD	1.5 NPT	2.0 NPT	2.0 NPT	2.0 NPT
Casing	Galv./SS	Galv./SS	Galv./SS	Galv./SS	Galv./SS	Galv./SS	Galv./SS	Galv./SS	Galv./SS	Galv./SS

Drain Pan Data

Table 23: Drain Pan Connections

Standard and optional stainless steel										
Arrangement	Unit size									
	002	003	004	005	007	010	015	020	025	030
Arrangement	Sloped	Sloped	Sloped	Sloped	Sloped	Sloped	Sloped	Sloped	Sloped	Sloped
Connection size - Main	1" ID MPT	1" ID MPT	1" ID MPT	1" ID MPT	1" ID MPT	1" ID MPT	1-1/4" ID MPT	1-1/4" ID MPT	1-1/4" ID MPT	1-1/4" ID MPT
Connection size - Secondary	1/2" ID MPT	1/2" ID MPT	1/2" ID MPT	1/2" ID MPT	1/2" ID MPT	1/2" ID MPT	1/2" ID MPT	1/2" ID MPT	1/2" ID MPT	1/2" ID MPT

Electric Heat Data

Table 24: Electric Heat Data for Unit Sizes

Unit size	Number of Stages	Voltage/kW Range							
		120/1/60	208/1/60	240/1/60	208/3/60	240/3/60	480/3/60	600/3/60	
002	1	1.5-4.5	1.5-8	1.5-9	1.5-10	1.5-10	1.5-10	1.5-10	
	2	4-9	4-9	4-10	4-10	4-10	4-10	4-10	
003	1	2.5-4.5	2.5-8	2.5-9	2.5-13	2.5-15	2.5-20	2.5-20	
	2	4-9	4-16	4-20	4-20	4-20	4-20	4-20	
	3	10-13	15-20	15-20	15-20	15-20	15-20	15-20	
	4	14-18	20	20	20	20	20	20	
004	1	2.5-4.5	2.5-8	2.6-9	2.5-13	2.5-15	2.5-20	2.5-20	
	2	4-9	4-16	4-18	4-20	4-20	4-20	4-20	
	3	9.5-13	15-20	15-20	15-20	15-20	15-20	15-20	
	4	14-18	20	20	20	20	20	20	
005	1	4-4.5	4-8	4-9	4-13	4-15	4-24	4-26	
	2	4-9	4-16	4-18	4-26	4-26	4-26	4-26	
	3	10-13	15-24	15-26	15-26	15-26	15-26	15-26	
	4	14-18	20-26	20-26	20-26	20-26	20-26	20-26	
007	1	NA	6-8	6-9	6-13	6-15	6-20	6-20	
	2	6-9	6-16	6-18	6-26	6-30	6-36	6-36	
	3	10-13	15-24	15-26	15-38	15-38	15-38	15-38	
	4	14-18	20-32	20-36	20-38	20-38	20-38	20-38	
010	1	NA	6-8	6-9	6-13	6-13	6-19	6-19	
	2	6-9	6-16	6-18	6-26	6-30	6-36	6-36	
	3	10-13	15-24	15-26	15-40	15-45	15-55	15-55	
	4	14-18	20-32	20-36	20-55	20-55	20-55	20-55	

Fan Curves

Figure 33: 9.0" SWSI - Backward Inclined Plenum Supply Fan at Standard Conditions

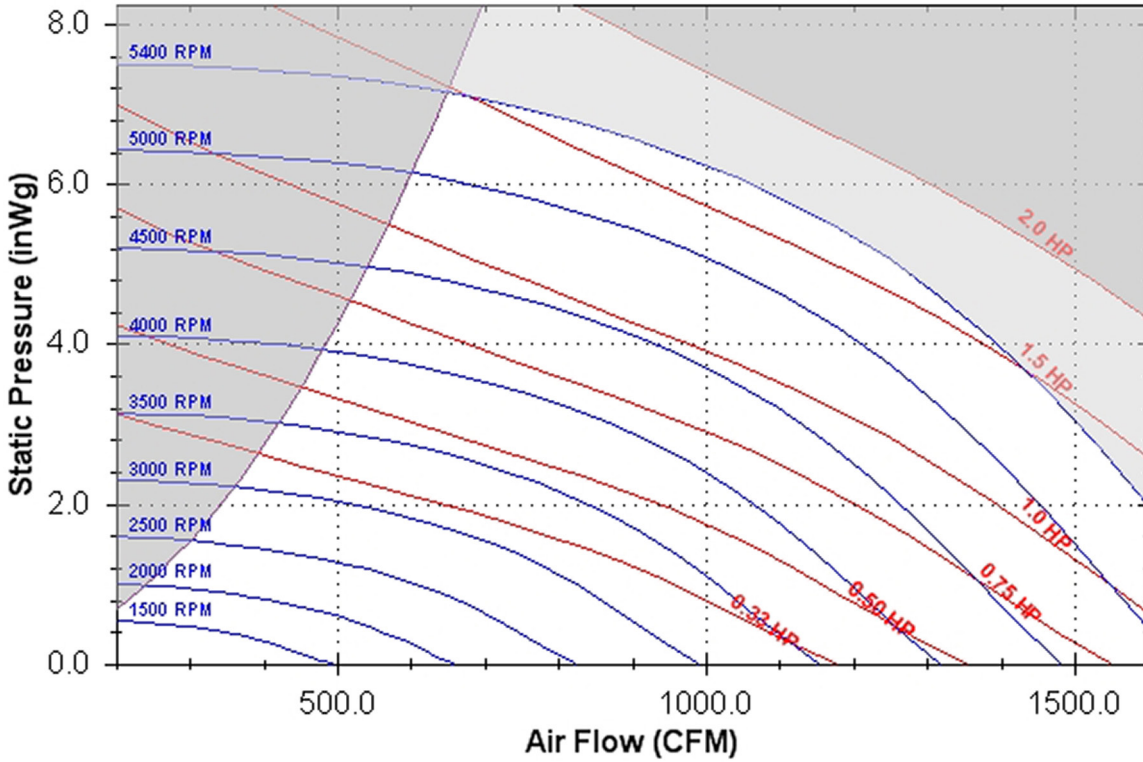

Figure 34: 10.0" SWSI - Backward Inclined Plenum Supply Fan at Standard Conditions

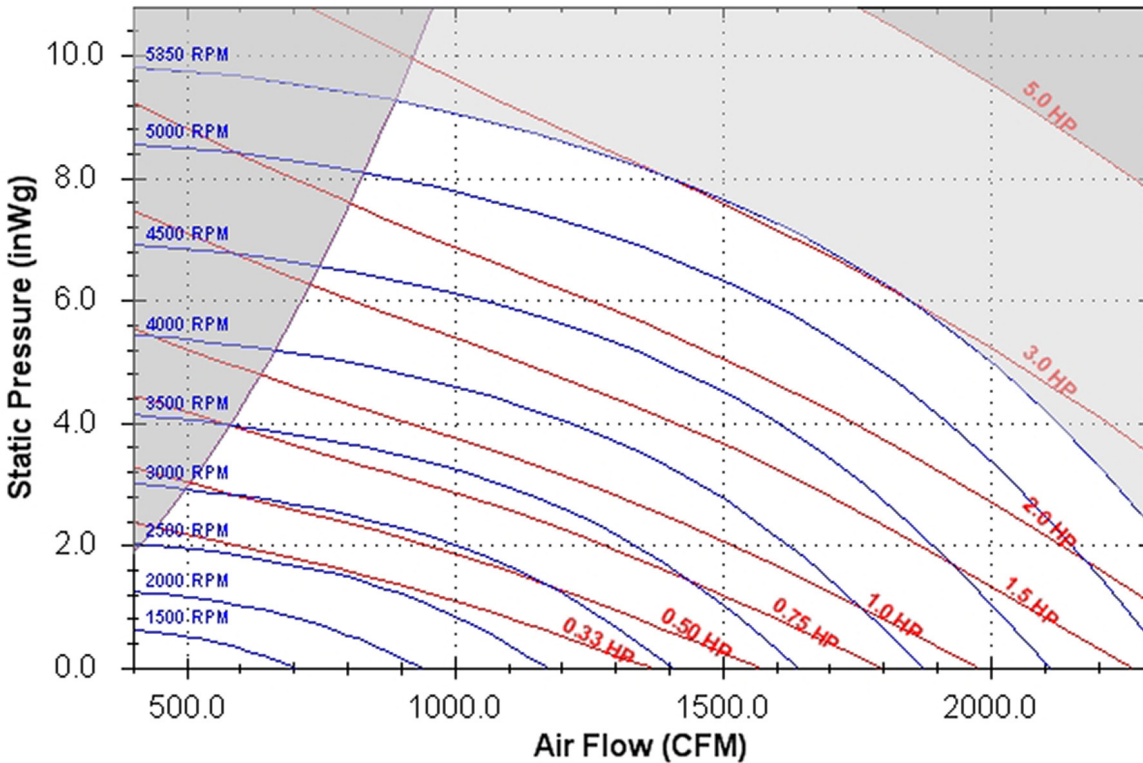

Figure 35: 11.0" SWSI - Backward Inclined Plenum Supply Fan at Standard Conditions

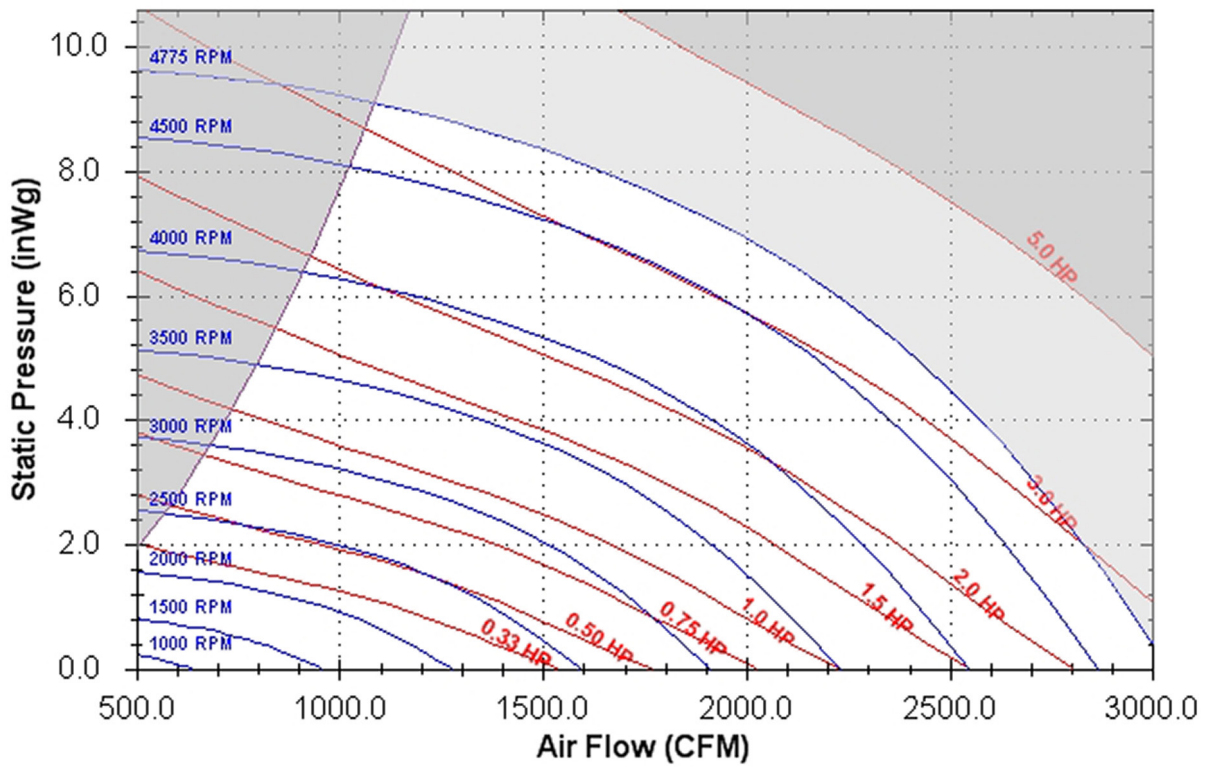

Figure 36: 12.0" SWSI - Backward Inclined Plenum Supply Fan at Standard Conditions

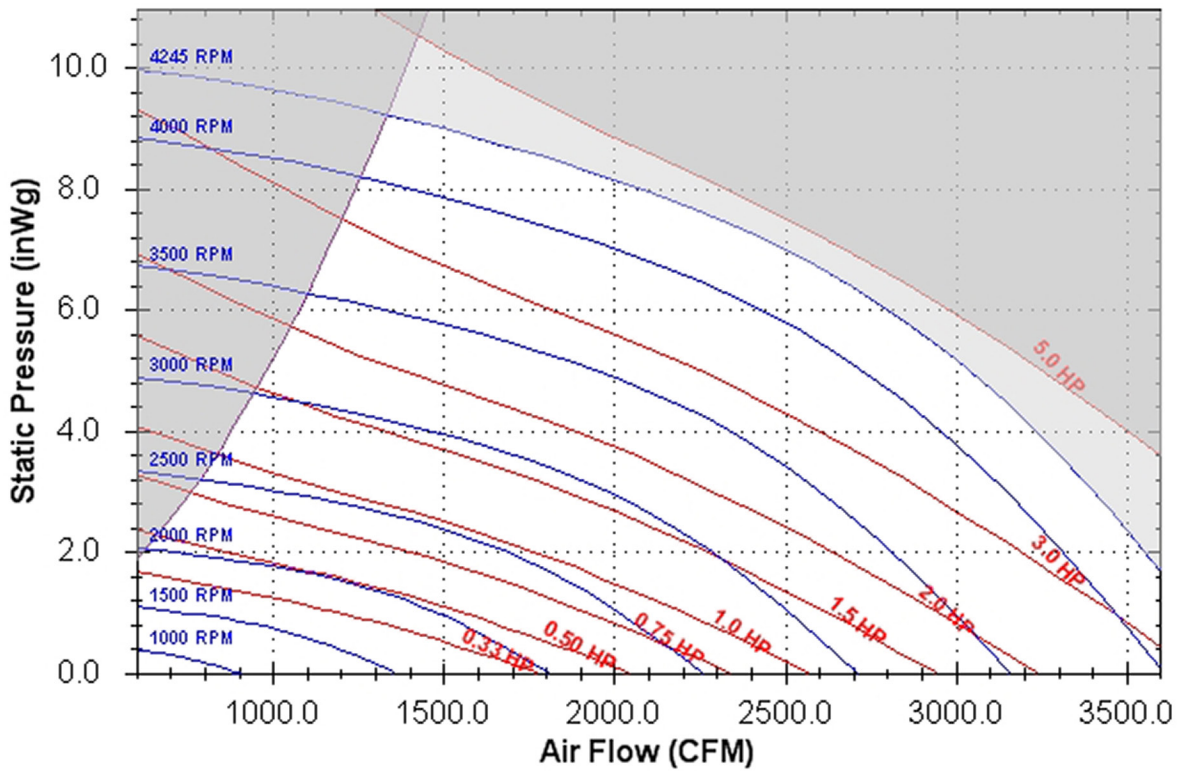

Figure 37: 14.0" SWSI - Backward Inclined Plenum Supply Fan at Standard Conditions

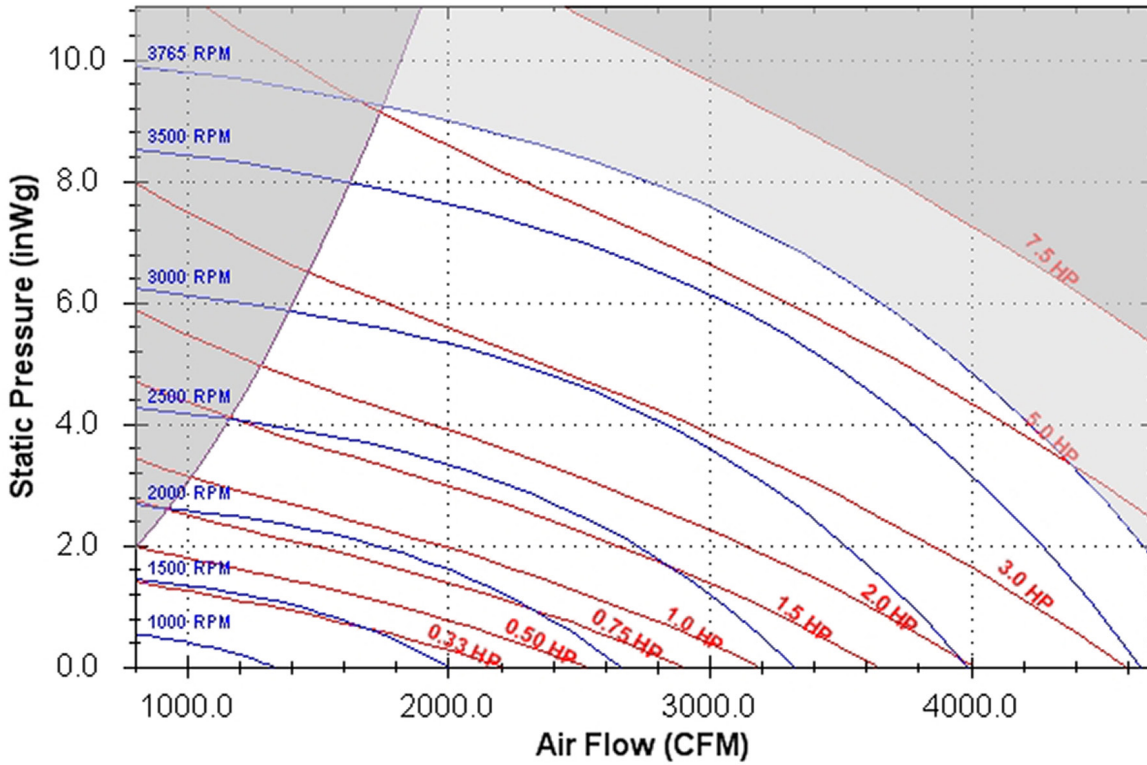

Figure 38: 16.0" SWSI - Backward Inclined Plenum Supply Fan at Standard Conditions

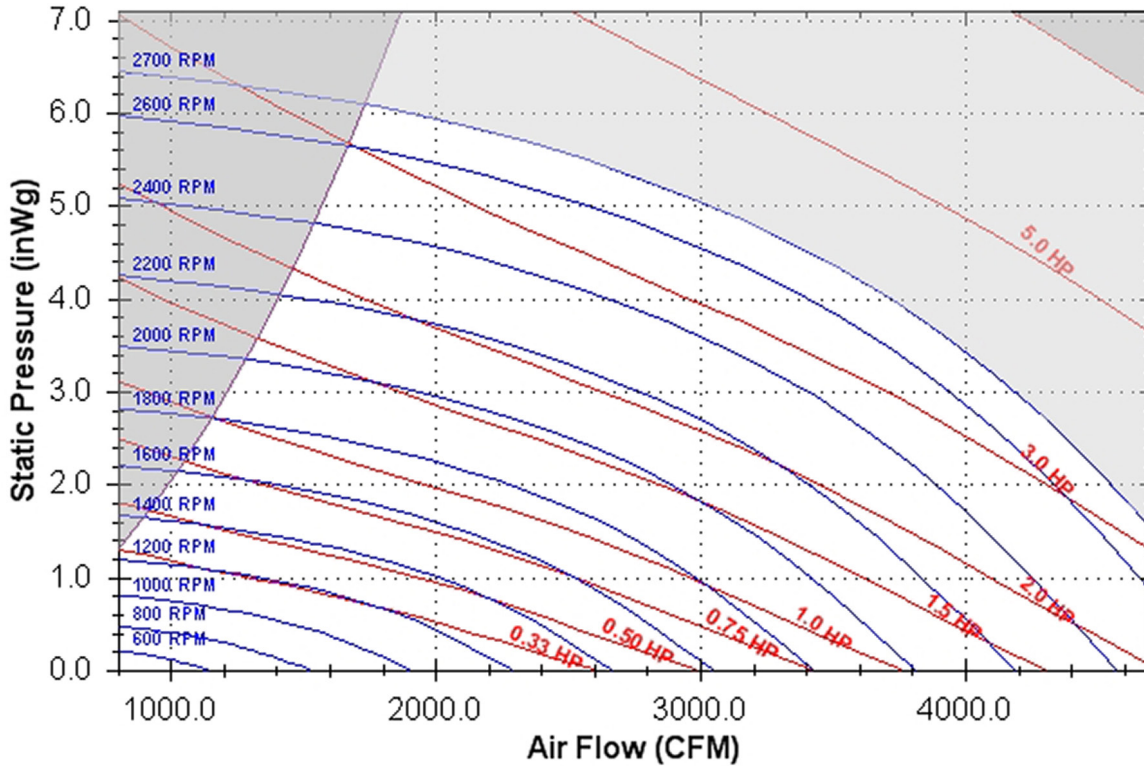

Figure 39: 20.0" SWSI - Backward Inclined Plenum Supply Fan at Standard Conditions

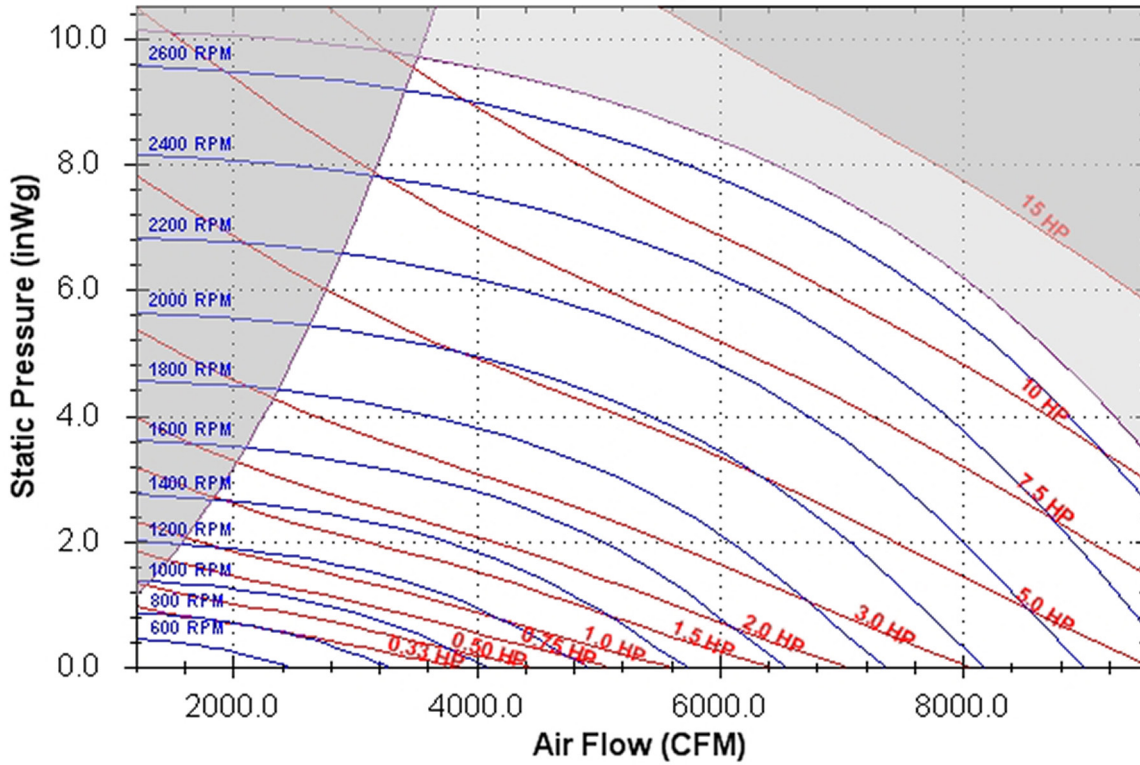

Figure 40: 22.0" SWSI - Backward Inclined Plenum Supply Fan at Standard Conditions

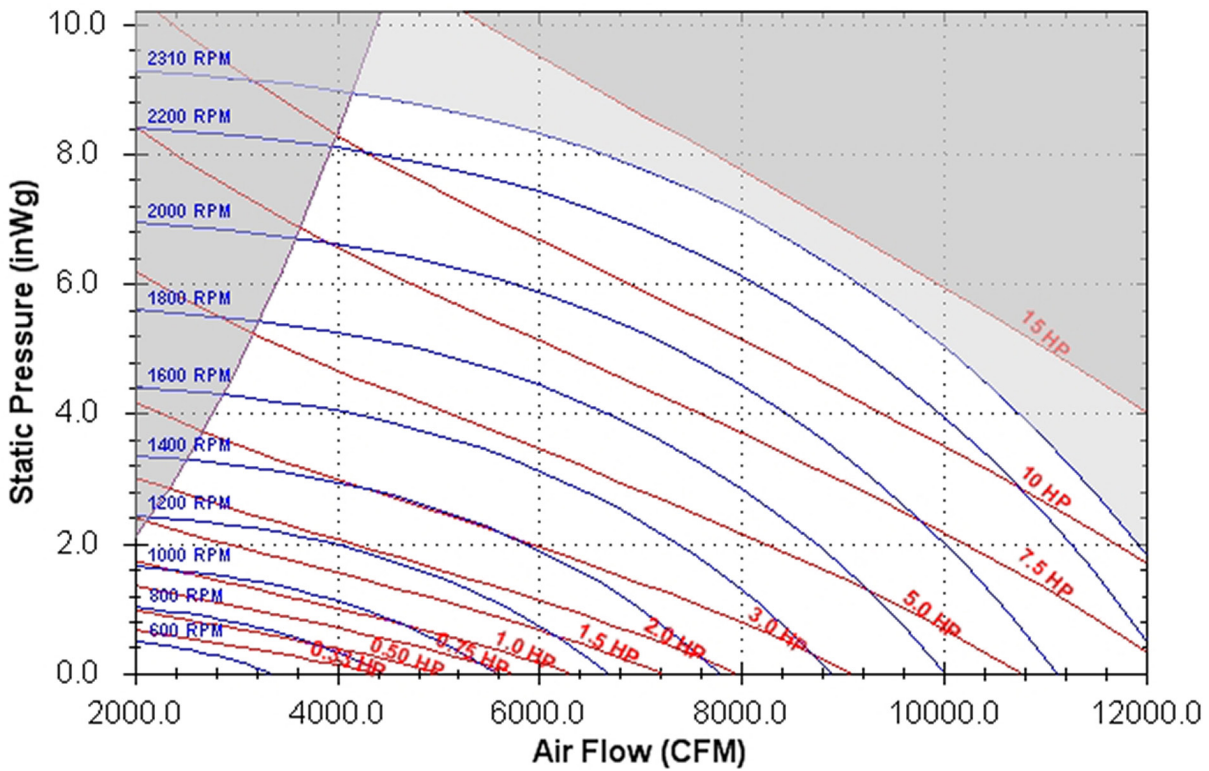
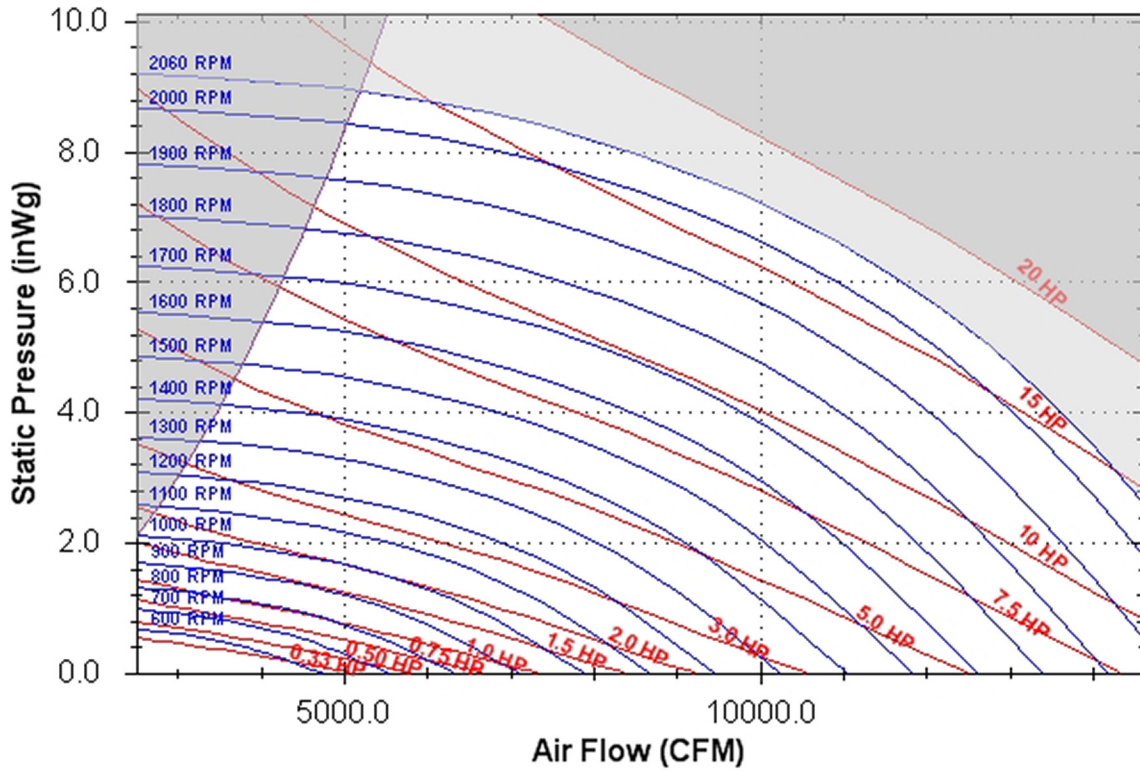

Figure 41: 25.0" SWSI - Backward Inclined Plenum Supply Fan at Standard Conditions



Cabinet Dimensions—Horizontal

Table 25: Cabinet Dimensions—Horizontal Unit

Dimension/ Configuration	Unit size										
	002	003	004	005	007	010	015	020	025	030	
Cabinet Dimension	Unit height and width dimensions in. (mm)										
Height	20.47 (520)	22.44 (570)	22.44 (570)	28.35 (720)	28.35 (720)	32.48 (825)	39.37 (1000)	51.57 (1310)	51.57 (1310)	59.06 (1500)	
Width	28.54 (725)	34.84 (885)	42.52 (1080)	42.52 (1080)	56.50 (1435)	63.00 (1600)	74.41 (1890)	75.00 (1905)	89.96 (2285)	89.96 (2285)	
Configuration	Unit length dimensions in. (mm)										
Cooling only or cooling with reheat coils	Flat filter	47.84 (1215)	47.84 (1215)	53.35 (1355)	54.72 (1390)	58.86 (1495)	58.86 (1495)	53.74 (1365)	56.30 (1430)	62.00 (1575)	62.00 (1575)
	Angular filter	58.27 (1480)	55.12 (1400)	60.63 (1540)	65.95 (1675)	70.08 (1780)	70.08 (1780)	64.37 (1635)	71.26 (1810)	76.97 (1955)	80.12 (2035)
Cooling with preheat coils	Flat filter	51.97 (1320)	51.97 (1320)	59.25 (1505)	59.45 (1510)	65.55 (1665)	65.55 (1665)	62.80 (1595)	65.35 (1660)	69.09 (1755)	69.09 (1755)
	Angular filter	62.40 (1585)	59.25 (1505)	66.53 (1690)	70.67 (1795)	76.77 (1950)	76.77 (1950)	73.42 (1865)	80.32 (2040)	84.06 (2135)	87.20 (2215)
Heating only	Flat filter	39.96 (1015)	39.96 (1015)	45.47 (1155)	45.67 (1160)	49.80 (1265)	49.80 (1265)	52.56 (1335)	55.51 (1410)	61.42 (1560)	61.42 (1560)
	Angular filter	50.39 (1280)	47.24 (1200)	52.76 (1340)	56.89 (1445)	61.02 (1550)	61.02 (1550)	63.19 (1605)	70.47 (1790)	76.38 (1940)	79.53 (2020)
Ventilation only	Flat filter	39.96 (1015)	39.96 (1015)	45.47 (1155)	45.67 (1160)	49.80 (1265)	49.80 (1265)	52.56 (1335)	55.51 (1410)	61.42 (1560)	61.42 (1560)
	Angular filter	50.39 (1280)	47.24 (1200)	52.76 (1340)	56.89 (1445)	61.02 (1550)	61.02 (1550)	63.19 (1605)	70.47 (1790)	76.38 (1940)	79.53 (2020)
Discharge Opening Dimension	Unit height and width dimensions in. (mm)										
Height	9.17 (233)	11.77 (299)	11.77 (299)	13.07 (332)	15.51 (394)	15.51 (394)	2 × 13.07* (332)	2 × 15.51* (394)	2 × 18.54* (471)	2 × 18.54* (471)	
Width	8.74 (222)	10.20 (259)	10.20 (259)	11.34 (288)	13.46 (342)	13.46 (342)	2 × 11.34* (288)	2 × 13.46* (342)	2 × 15.83* (402)	2 × 15.83* (402)	

NOTE: * Twin openings

Figure 42: Horizontal Unit Dimensions

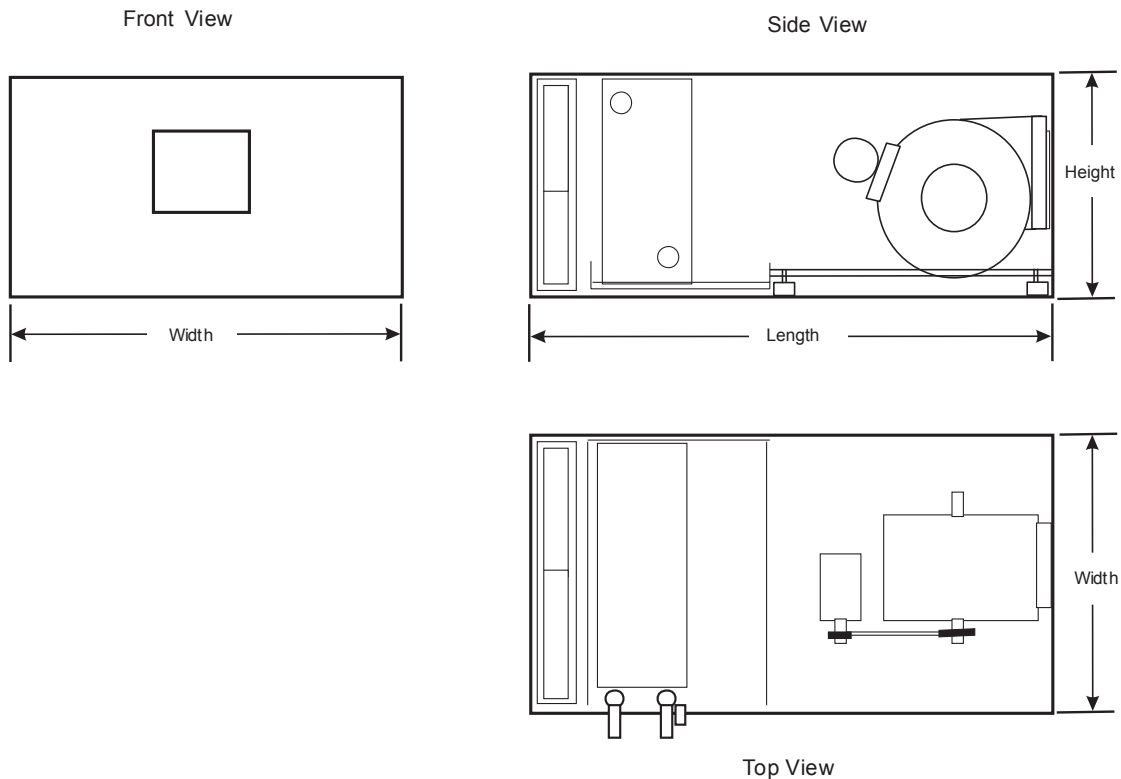
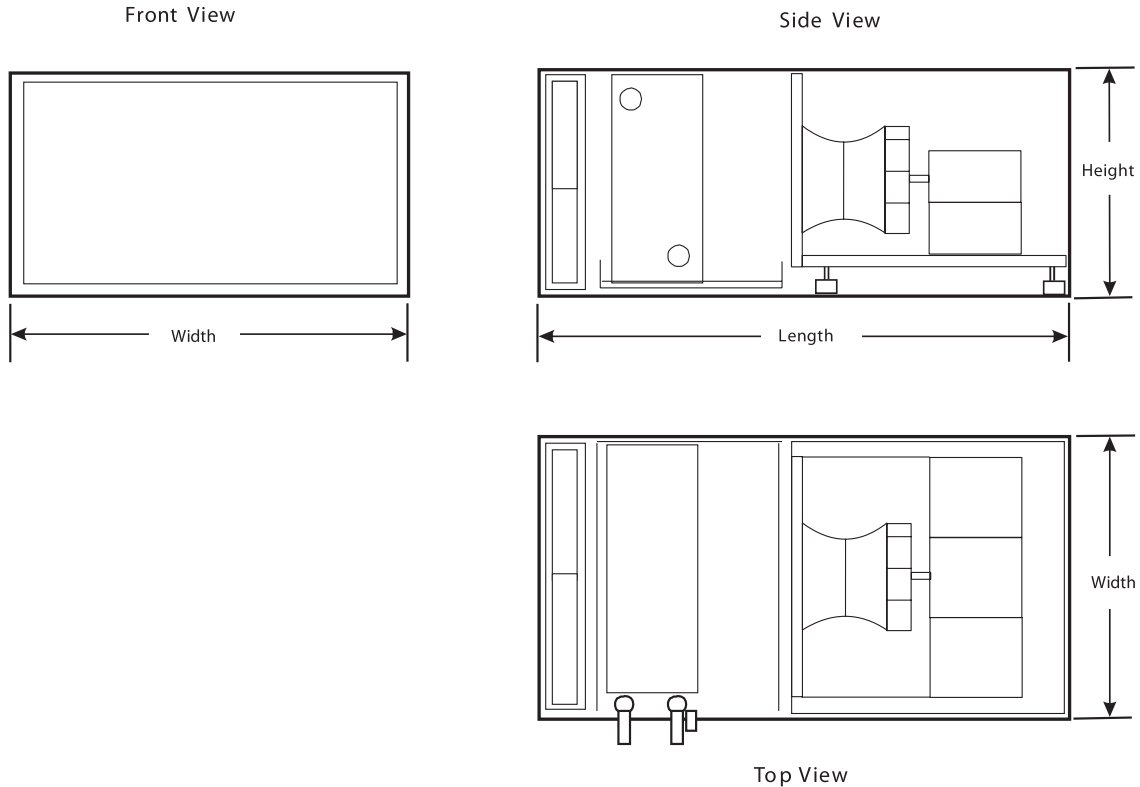

Table 26: Cabinet Dimensions—Horizontal Unit with Plenum Fan

Dimension/ Configuration		Unit size									
		002	003	004	005	007	010	015	020	025	030
Cabinet Dimension		Unit height and width dimensions in. (mm)									
Height		20.47 (520)	22.44 (570)	22.44 (570)	28.35 (720)	28.35 (720)	32.48 (825)	39.37 (1000)	51.57 (1310)	51.57 (1310)	59.06 (1500)
Width		28.54 (725)	34.84 (885)	42.52 (1080)	42.52 (1080)	56.50 (1435)	63.00 (1600)	74.41 (1890)	75.00 (1905)	89.96 (2285)	89.96 (2285)
Configuration		Unit length dimensions in. (mm)									
Cooling only or cooling with reheat coils	Flat filter	47.83 (1215)	53.94 (1370)	59.45 (1510)	62.01 (1575)	70.08 (1780)	70.08 (1780)	70.87 (1800)	78.35 (1990)	88.54 (2250)	88.54 (2250)
	Angular filter	58.27 (1480)	61.42 (1560)	66.54 (1690)	73.03 (1855)	81.50 (2070)	81.50 (2070)	81.50 (2070)	93.31 (2370)	103.54 (2630)	106.69 (2710)
Cooling with preheat coils	Flat filter	51.97 (1320)	58.27 (1480)	62.99 (1600)	66.73 (1695)	76.77 (1950)	76.77 (1950)	79.92 (2030)	87.40 (2220)	95.67 (2430)	95.67 (2430)
	Angular filter	62.40 (1585)	65.55 (1665)	70.08 (1780)	77.76 (1975)	88.19 (2240)	88.19 (2240)	90.55 (2300)	102.36 (2600)	110.63 (2810)	95.67 (2430)
Heating only	Flat filter	39.96 (1015)	46.06 (1170)	51.57 (1310)	52.95 (1345)	61.02 (1550)	61.02 (1550)	69.69 (1770)	77.56 (1970)	88.19 (2240)	88.19 (2240)
	Angular filter	50.79 (1290)	53.54 (1360)	58.66 (1490)	63.98 (1625)	72.44 (1840)	72.44 (1840)	80.31 (2040)	92.52 (2320)	103.15 (2620)	105.91 (2690)
Ventilation only	Flat filter	39.96 (1015)	46.06 (1170)	51.57 (1310)	52.95 (1345)	61.02 (1550)	61.02 (1550)	69.69 (1770)	77.56 (1970)	88.19 (2240)	88.19 (2240)
	Angular filter	50.79 (1290)	53.54 (1360)	58.66 (1490)	63.98 (1625)	72.44 (1840)	72.44 (1840)	80.31 (2040)	92.52 (2320)	103.15 (2620)	105.91 (2690)
Discharge Opening Dimension		Unit height and width dimensions in. (mm)									
Height		18.11 (460)	20.08 (510)	20.08 (510)	25.98 (660)	25.98 (660)	30.11 (765)	37.00 (940)	49.21 (1250)	49.21 (1250)	56.69 (2225)
Width		26.18 (665)	32.48 (825)	40.16 (1020)	40.16 (1020)	54.13 (1375)	60.63 (1540)	72.05 (1830)	72.64 (1845)	87.60 (2225)	87.60 (2225)

Figure 43: Horizontal Unit Dimensions



Cabinet Dimensions—Vertical

Table 27: Cabinet Dimensions—Vertical Unit

Dimensions	Unit size									
	002	003	004	005	007	010	015	020	025	030
Cabinet Dimension	Unit height, length, and width dimensions in. (mm)									
Width, in (mm)	28.54 (725)	34.84 (885)	42.52 (1080)	42.52 (1080)	56.50 (1435)	62.99 (1600)	74.41 (1890)	75.00 (1905)	89.96 (2285)	89.96 (2285)
Length, in (mm)	29.92 (760)	33.07 (840)	33.07 (840)	36.42 (925)	39.96 (1015)	39.96 (1015)	42.72 (1085)	47.83 (1215)	51.18 (1300)	51.18 (1300)
Upper section height, in (mm)	17.13 (435)	19.88 (505)	19.88 (505)	22.05 (560)	24.61 (625)	24.61 (625)	23.82 (605)	26.97 (685)	31.30 (795)	31.30 (795)
Lower section height, in (mm)	20.47 (520)	22.44 (570)	22.44 (570)	28.35 (720)	28.35 (720)	32.48 (825)	39.37 (1000)	51.57 (1310)	51.57 (1310)	59.06 (1500)
Discharge Opening Dimensions	Unit height and width dimensions, in. (mm)									
Height, in (mm)	9.17 (233)	11.77 (299)	11.77 (299)	13.07 (332)	15.51 (394)	15.51 (394)	13.07* (332)	15.51* (394)	18.54* (471)	18.54* (471)
Width, in (mm)	8.74 (222)	10.20 (259)	10.20 (259)	11.34 (288)	13.46 (342)	13.46 (342)	11.34 (288)	13.46 (342)	15.83 (402)	15.83 (402)

NOTE: * Twin openings

Figure 44: Vertical Unit Dimensions

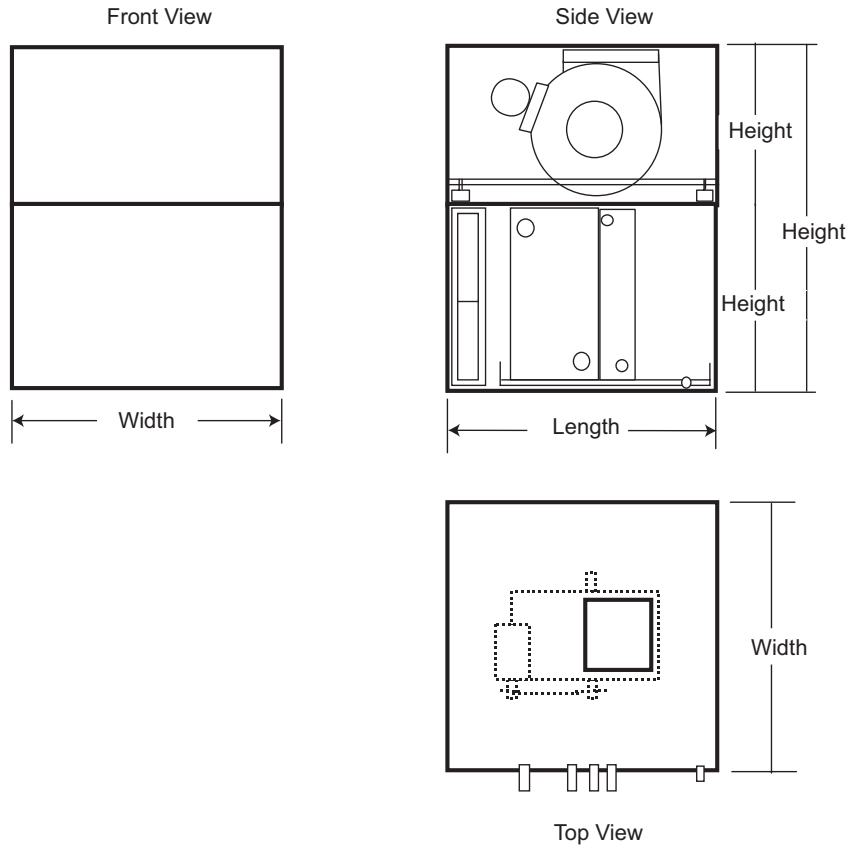

Mixing Box Dimensions

Table 28: Horizontal and Vertical Units

Unit size	Cabinet, in. (mm)			Damper, in. (mm)		Area (ft ²)
	W	H	L	W1	L1	
002	28.54 (725)	20.47 (520)	10.24 (260)	26.18 (665)	7.87 (200)	1.43
003	34.84 (885)	22.44 (570)	10.24 (260)	32.48 (825)	7.87 (200)	1.78
004	42.52 (1080)	22.44 (570)	10.24 (260)	40.16 (1020)	7.87 (200)	2.20
005	42.52 (1080)	28.35 (720)	14.17 (360)	40.16 (1020)	11.81 (300)	3.29
007	56.50 (1435)	28.35 (720)	14.17 (360)	54.13 (1375)	11.81 (300)	4.44
010	62.99 (1600)	32.48 (825)	14.17 (360)	60.63 (1540)	11.81 (300)	4.97
015	74.41 (1890)	39.37 (1000)	18.11 (460)	72.05 (1830)	15.75 (400)	7.88
020	75.00 (1905)	51.57 (1310)	25.98 (660)	72.64 (1845)	23.62 (600)	11.92
025	89.96 (2285)	51.57 (1310)	25.98 (660)	87.60 (2225)	23.62 (600)	14.37
030	89.96 (2285)	59.06 (1500)	29.92 (760)	87.60 (2225)	27.56 (700)	16.76

Figure 45: Mixing Box Dimensions

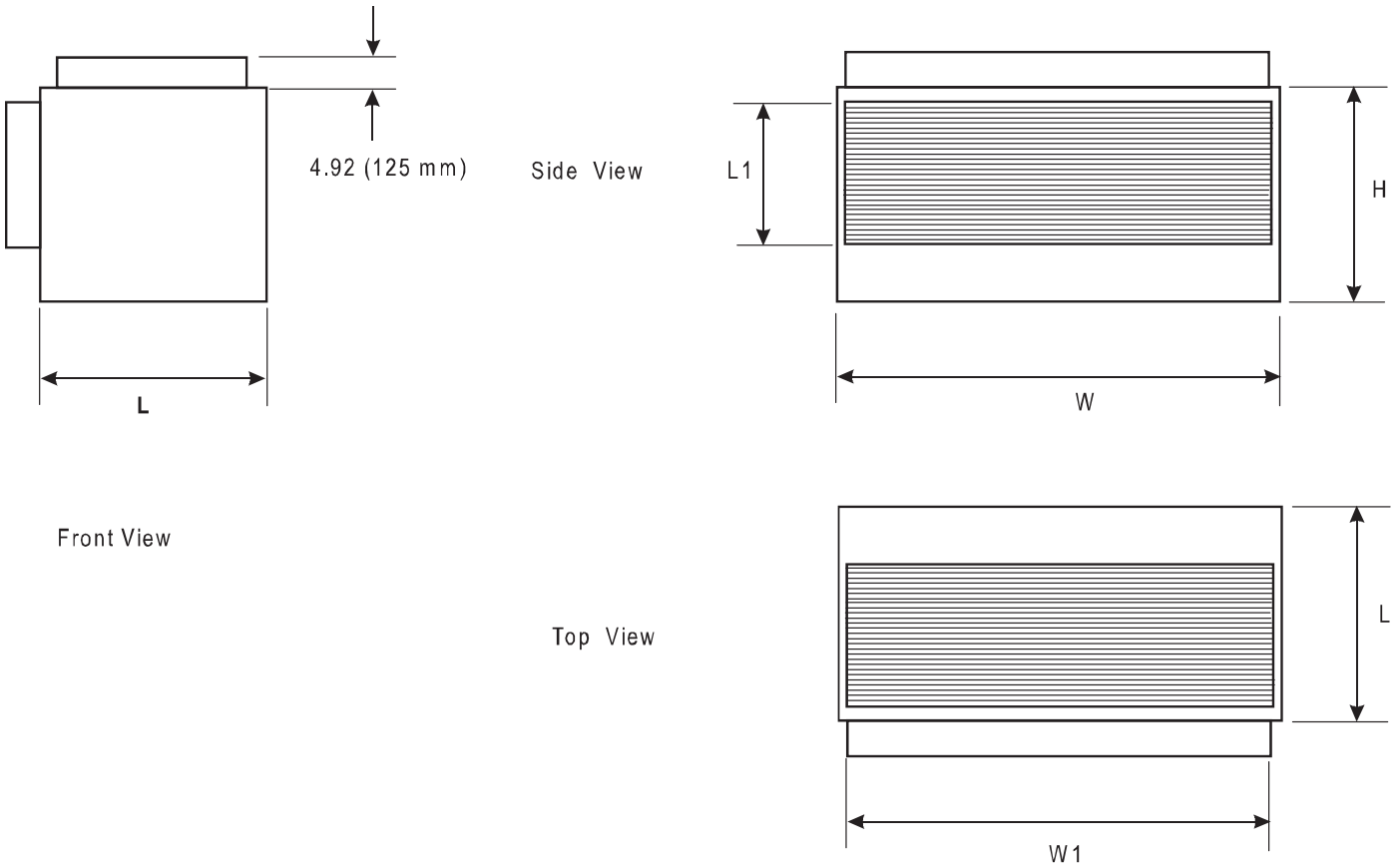

Electric Heat Dimensions—Left/Right Oriented

Table 29: Electric Heat Dimensions - in. (mm), Sizes 002 through 004

Dimension, in. (mm)	Unit Size										
	002		003				004				
	1 Step	2 Steps	1Step	2 Steps	3 Steps	4 Steps	1Step	2 Steps	3 Steps	4 Steps	
A	9-1/2 (241)	9-1/2 (241)	9-1/2 (241)	9-1/2 (241)	9-1/2 (241)	9-1/2 (241)	9-1/2 (241)	9-1/2 (241)	9-1/2 (241)	9-1/2 (241)	9-1/2 (241)
B	20 (508)	20 (508)	22-1/4 (565)	22-1/4 (565)	22-1/4 (565)	22-1/4 (565)	22-1/4 (565)	22-1/4 (565)	22-1/4 (565)	22-1/4 (565)	22-1/4 (565)
C	11-1/2 (292)	16 (406)	11-1/2 (292)	16 (406)	20 (508)	24 (610)	11-1/2 (292)	16 (406)	20 (508)	24 (610)	
D	8-3/4 (222)	8-3/4 (222)	10-3/8 (264)	10-3/8 (264)	10-3/8 (264)	10-3/8 (264)	10-3/8 (264)	10-3/8 (264)	10-3/8 (264)	10-3/8 (264)	10-3/8 (264)
E	3/4 (19)	3/4 (19)	3/4 (19)	3/4 (19)	3/4 (19)	3/4 (19)	3/4 (19)	3/4 (19)	3/4 (19)	3/4 (19)	3/4 (19)
F	10 (254)	10 (254)	12-3/4 (324)	12-3/4 (324)	12-3/4 (324)	12-3/4 (324)	12-3/4 (324)	12-3/4 (324)	12-3/4 (324)	12-3/4 (324)	12-3/4 (324)
G	3/4 (19)	3/4 (19)	3/4 (19)	3/4 (19)	3/4 (19)	3/4 (19)	3/4 (19)	3/4 (19)	3/4 (19)	3/4 (19)	3/4 (19)
H	9-1/4 (235)	9-1/4 (235)	12 (305)	12 (305)	12 (305)	12 (305)	12 (305)	12 (305)	12 (305)	12 (305)	12 (305)

Table 30: Electric Heat Dimensions - in. (mm), Sizes 005 through 010

Dimension, in. (mm)	Unit Size											
	005				007				010			
	1Step	2 Steps	3 Steps	4 Steps	1Step	2 Steps	3 Steps	4 Steps	1Step	2 Steps	3 Steps	4 Steps
A	9-1/2 (241)	9-1/2 (241)	9-1/2 (241)	9-1/2 (241)	9-1/2 (241)	9-1/2 (241)	9-1/2 (241)	9-1/2 (241)	9-1/2 (241)	9-1/2 (241)	9-1/2 (241)	9-1/2 (241)
B	23-1/2 (597)	23-1/2 (597)	23-1/2 (597)	23-1/2 (597)	25 (635)	25 (635)	25 (635)	25 (635)	25 (635)	25 (635)	25 (635)	25 (635)
C	11-1/2 (292)	16 (406)	20 (508)	24 (610)	11-1/2 (292)	16 (406)	20 (508)	24 (610)	11-1/2 (292)	16 (406)	20 (508)	24 (610)
D	11-3/8 (289)	11-3/8 (289)	11-3/8 (289)	11-3/8 (289)	13-1/2 (343)	13-1/2 (343)	13-1/2 (343)	13-1/2 (343)	13-1/2 (343)	13-1/2 (343)	13-1/2 (343)	13-1/2 (343)
E	3/4 (19)	3/4 (19)	3/4 (19)	3/4 (19)	3/4 (19)	3/4 (19)	3/4 (19)	3/4 (19)	3/4 (19)	3/4 (19)	3/4 (19)	3/4 (19)
F	14 (356)	14 (356)	14 (356)	14 (356)	16-1/2 (419)	16-1/2 (419)	16-1/2 (419)	16-1/2 (419)	16-1/2 (419)	16-1/2 (419)	16-1/2 (419)	16-1/2 (419)
G	3/4 (19)	3/4 (19)	3/4 (19)	3/4 (19)	3/4 (19)	3/4 (19)	3/4 (19)	3/4 (19)	3/4 (19)	3/4 (19)	3/4 (19)	3/4 (19)
H	13-1/4 (337)	13-1/4 (337)	13-1/4 (337)	13-1/4 (337)	15-3/4 (400)	15-3/4 (400)	15-3/4 (400)	15-3/4 (400)	15-3/4 (400)	15-3/4 (400)	15-3/4 (400)	15-3/4 (400)

Figure 46: Electric Heat Dimensions

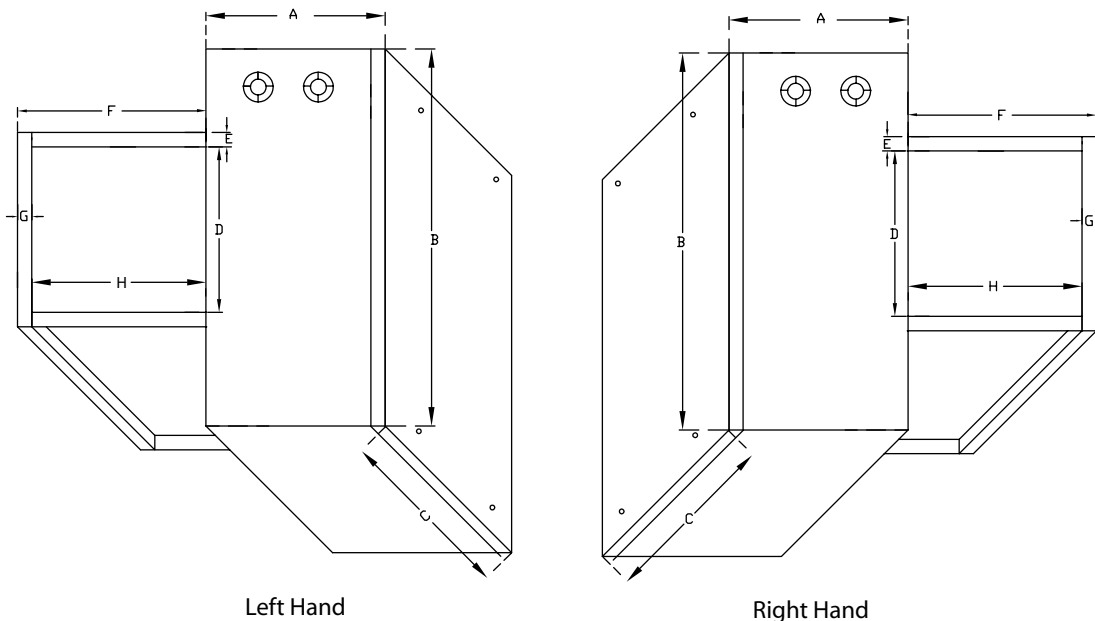

NOTE: Heaters are not intended to be installed with less than 20" of straight duct at the outlet of the heater.

Control Box Dimensions

Table 31: Control Box Dimensions – Left and Right Hand Access

Dimension/Configuration	Unit size									
	002	003	004	005	007	010	015	020	025	030
Disconnect/Starter/Transformer	Dimensions, in. (mm)									
Width	8 (203)	8 (203)	8 (203)	8 (203)	8 (203)	8 (203)	12 (305)	12 (305)	12 (305)	12 (305)
Depth	6 (152)	6 (152)	6 (152)	6 (152)	6 (152)	6 (152)	6 (152)	6 (152)	6 (152)	6 (152)
Height	18 (407)	18 (407)	18 (407)	18 (407)	18 (407)	18 (407)	16 (415)	16 (415)	16 (415)	16 (415)
Disconnect Only/Left Hand Access Only	Dimensions, in. (mm)									
Width	7 (178)	7 (178)	7 (178)	7 (178)	7 (178)	9 (223)	9 (223)	9 (223)	9 (223)	9 (223)
Depth	5 (125)	5 (125)	5 (125)	5 (125)	5 (125)	6.5 (162)	6.5 (162)	6.5 (162)	6.5 (162)	6.5 (162)
Height	15 (378)	15 (378)	15 (378)	15 (378)	15 (378)	17.5 (444)	17.5 (444)	17.5 (444)	21.3 (540)	21.3 (540)

Figure 47: Control Box Dimensions

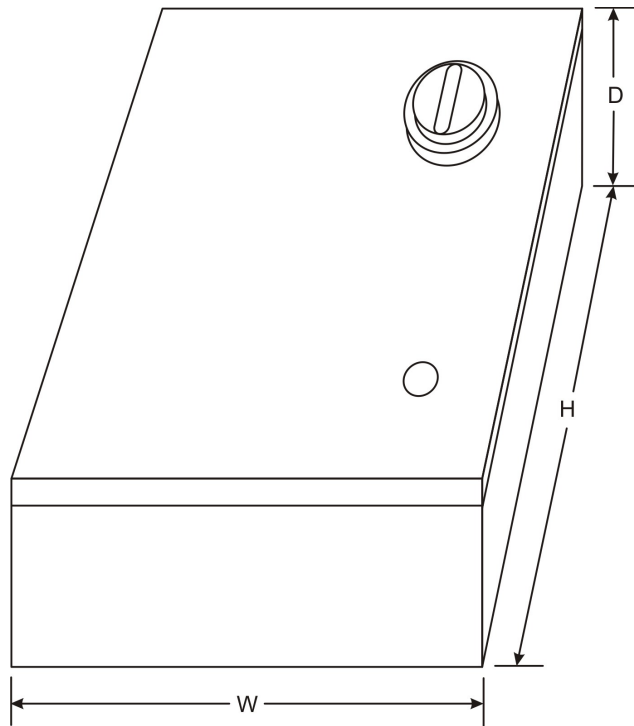

Startup Checks

WARNING

ROTATING FAN

Can cause severe injury or death. Before servicing fans, lockout and tag out power.

DANGER

FIRE/ELECTRIC SHOCK HAZARD

Can cause property damage, personal injury or death. Wire fan power supply and ground motor frame in accordance with local electric codes.

DANGER

FAN MOTOR REQUIRES OVERLOAD PROTECTION

Failure to provide motor overload protection can result in fire, property damage, electric shock, personal injury or death. Connect motor to an overload protective device rated in compliance with local electric codes.

WARNING

DO NOT OVERHEAT FAN MOTOR

High air temperatures the fan section can cause the fan motor to burnout. On draw-through air handlers or air handlers with the fan section down the air stream from the heating section, the discharge air temperature of the heating section must not exceed 104°F (40°C).

CAUTION

Cautions indicate potentially hazardous situations, which can result in personal injury or equipment damage if not avoided.

When performing startup and service, always take thorough safety precautions. Start-up functions must be performed by trained, experienced personnel.

Before Starting the Unit

Make sure that fan electrical power source is disconnected and locked in the OFF position before entering fan section.

1. With ductwork connected, check the unit for complete and proper installation.
2. Check that all construction debris is removed and filters are clean.
3. Check that all electrical work is complete and properly terminated. Check that all electrical connections are tight and that the proper voltage is connected. Phase imbalance must not exceed 2%.
4. Ball bearings on fan shaft and motor are prelubricated and do not need grease before startup.
5. Check tightness of setscrews in bearings and fan wheel(s). If retightening is needed, make certain the fan wheel(s) are aligned properly or setscrews are torqued per [Table 38 on page 51](#).
6. Check alignment of fan and motor sheaves and belt tension. Adjust if necessary. Check tightness of sheave setscrews and/or capscrews. See [Figure 49 on page 47](#) and [Figure 50 on page 48](#) and [Figure 51 on page 49](#).
7. Leak test the thermal system to verify that connections are tight.
8. Check that condensate drain is trapped.
9. Rotate shaft by hand to be sure it is free.
10. Fan startup: Fan should start and run. Observe the rotation. If the fan is operating backward, reverse two legs of the three-phase supply power.

NOTE: Variable pitch fan drives are usually provided for operation in the mid-speed adjustment range. However, the drives usually ship with the adjustment opened for minimum fan speed. Adjust the drives for the proper airflow. Refer to [Fan Drive Adjustments on page 47](#).

After first 48 hours of operation:

1. Disconnect and lockout electrical power source.
2. Check tightness of all bearing, wheel, and sheave setscrews (or capscrews). See [Table 32](#).
3. Recheck belt tension and adjust if necessary. Belts tensioned sufficiently to slip one to two seconds at startup will perform satisfactorily, extending life and reducing vibration. If retensioning is necessary, be certain to retain sheave alignment.

Table 32: Bearing Collar and Wheel Hub Setscrew Torque

Setscrew Diameter, in	Minimum torque, ft/lbs (kg/M)
1/4	5.5 (0.76)
1/16	10.5 (1.45)
3/8	19.0 (2.63)
7/16	29.0 (4.01)

Operating Limits

Do not exceed the operating limits in [Table 33](#) and [Table 34](#). A fan wheel that is operated beyond the rpm and temperature limits shown may suffer permanent distortion or fracture. The resulting unbalance may cause severe unit vibration.

Table 33: Forward Curved Fan Operating Limits

Forward curved—housed							
Dia., (in)	7-7	9-9	10-10	12-12	Twin 10"	Twin 12"	Twin 15"
Max. rpm	2680	2650	2100	1700	2100	1700	1500

Table 34: Backward Inclined Plenum Fan Operating Limits

Backward inclined —plenum						
Dia., (in)	9	10	11	12.5	14	16
Max. rpm	2680	2650	2100	1700	2100	1700
Dia., (in)	18	20	22	25	28	
Max. rpm	1500	2675	2310	2060	1840	

For units with direct drive plenum fans employing variable frequency drives, use the formula below to calculate the maximum allowable frequency associated with the maximum allowable fan speed.

$$F_{\max} = 60 \text{ Hz} \times (W_{\max} / W_{\text{motor}})$$

F_{\max} – maximum frequency allowable for particular application (Hz)

W_{\max} – maximum fan speed (rpm); refer to fan curves ([Figure 33](#) through [Figure 41](#))

W_{motor} – nominal motor speed (1800/3600 rpm); refer to motor nameplate

Fan Vibration Levels

Each unit as shipped is trim balanced to operate smoothly. To provide satisfactory operation after shipping and installation, use the accepted industry guidelines for field balancing fans. Vibration ≤ 0.20 in/sec.

NOTE: Excessive vibration from any cause contributes to premature fan and motor bearing failure. Monitor overall vibration levels every six months of operation. An increase in levels is an indication of potential trouble.

Vibration Causes

1. Wheel imbalance
 - a. Dirt or debris on wheel blades
 - b. Loose setscrews in wheel hub or bearing-to-shaft
 - c. Wheel distorted from overspeed
2. Bent shaft
3. Drive faulty
 - a. Variable pitch sheaves—Axial and radial runout of flanges, uneven groove spacing, out of balance. Also similar faults in driven sheave.
 - b. Bad V-belts, lumpy or mismatched, belt tension too tight or too loose
4. Bad bearings, loose bearing hold-down bolts
5. Motor imbalance
6. Fan section not supported evenly on foundation

Periodic Service and Maintenance

1. Check all moving parts for wear every six months.
2. Check bearing collar, sheave, and wheel hub setscrews, sheave capscrews, and bearing hold-down bolts for tightness every six months.

Ball Bearing Lubrication

1. Motor bearings—All ball bearings are prelubricated and do not require additional grease during installation. However, periodic cleaning out and renewal of grease is necessary. Exercise extreme care when cleaning to prevent foreign matter from entering the bearing. It is also important to avoid over greasing. Only use a high grade, clean mineral grease with the following characteristics.
 - a. Melting point preferably over 302°F (150°C).
 - b. Does not separate by oil and soap under operating and storage conditions.
 - c. Free of abrasive matter, acid, alkali, and moisture.
 - d. Specific greasing instructions are located on a label attached to the fan section door.
2. Fan shaft bearings—All ball bearings are prelubricated and do not require additional grease during installation. Periodic greasing is necessary. Bearings are accessible in the fan section. A grease fitting is located on each side of the fan shaft. Do not over lubricate. Wipe off any excess grease to prevent overheating. The lubrication interval varies with the period of operation and temperature of the ambient air. Use the guidelines in the [Table 36](#).

Table 35: Bearing Operating Temperature Range

Operation	To 130°F (54°C)	To 150°F (66°C)	Over 150°F (66°C)
Continuous operation	6 months	4 months	2 months
12-hr/day operation	12 months	12 months	6 months

Table 36: Lubricants Recommended for Fan Shaft Ball Bearings

Manufacturer	Product name	Temperature range, °F (°C)
Texaco Lubricants Company	Premium RB	-30 to 300 (-34 to 149)
Keystone Ind. Lubricants	81EP-2	0 to 250 (-18 to 121)
Mobil Oil Corporation	Mobilith SCH100	-40 to 350 (-40 to 177)
Exxon Company, U.S.A.	Ronex MP	-40 to 300 (-40 to 149)
Shell Oil Company	Alvania No. 2	-20 to 240 (-29 to 116)

NOTE: Temperature ranges over 225°F are shown for lubricants only. High temperature applications are not suitable for standard air handler components.

Figure 48: Fan Shaft Bearing Grease Fitting

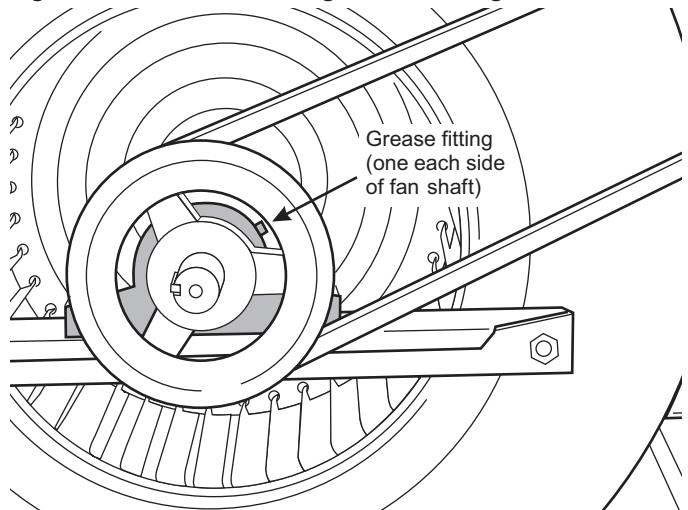

Fan Drive Adjustments

WARNING

ROTATING FAN can use severe injury or death. Before servicing fans, lockout and tag out power.

Do not open the hinged access door and access panels while the unit is operating. Moving parts and strong suction forces can cause severe personal injury or death.

Before entering any fan section, make sure the electrical power source to the fan motor is disconnected, locked out and tagged out.

Upon completion of the air balance, replace the variable pitched motor sheave with a properly sized, fixed sheave. A matching fixed sheave provides longer belt and bearing life and vibration-free operation. Initially, it is best to have a variable pitched motor sheave for the purpose of air balancing. Once the balance is achieved, fixed sheaves maintain balancing and alignment more effectively. Replace the adjustable sheaves with fixed sheaves.

With the electrical power disconnected, locked and tagged out, measure the diameter of the V-belt outer surface where it passes around the sheave (pitch diameter). Calculate fan speed from the motor nameplate rpm.

$$\text{Fan rpm} = \text{Motor rpm} \times \frac{\text{Measured diameter at motor sheave}}{\text{Measured diameter at fan sheave}}$$

Figure 49: VP Type Sheave Adjustment

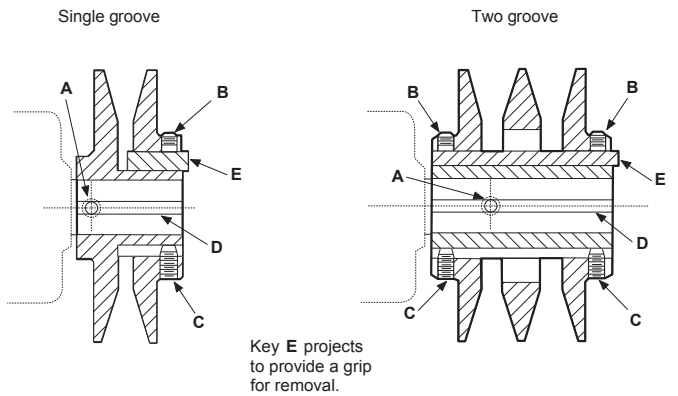

Note: Do not operate sheave with flange projecting beyond the hub end.

VM and VP Variable Pitch Key Type Sheaves

Mounting:

1. Mount all sheaves on the motor or driving shaft with the setscrews A toward the motor. See [Figure 49](#).
2. Verify that both driving and driven sheaves are in alignment and that shafts are parallel.
3. Fit internal key D between sheave and shaft and lock setscrew A securely in place.

Adjusting:

1. Loosen setscrews B and C in moving parts of sheave and pull out external key E. (This key projects a small amount to provide a grip for removing.)
2. Adjust sheave pitch diameter for desired speed by opening moving parts by half or full turns from closed position.

Do not open more than five full turns for A belts or six full turns for B belts.
3. Replace external key E and securely tighten setscrews B over key and setscrews C into keyway in fixed half of the sheave.
4. Put on belts and adjust belt tension. **Do not force belts over grooves.** See [Fan Drive Belt Adjustment on page 50](#).
5. Make future adjustments by loosening the belt tension and increasing or decreasing the pitch diameter of the sheave by half or full turns as required. Readjust belt tension before starting drive.
6. Adjust both halves of two-groove sheaves the same number of turns from closed-groove position to provide the same pitch diameter.
7. Verify that all keys are in place and that all setscrews are tight before starting drive. Check setscrews and belt tension after 24 hours service.

LVP Variable Speed Sheaves

Mounting:

1. Slide sheave on motor shaft so that the side of the sheave with setscrew A is next to the motor, when setscrew A is in the hub or barrel of the sheave. See [Figure 51](#).
2. When setscrew A is at an angle in the center flange B, mount it away from the motor so the outer locking ring and flange can be removed to get to the setscrew.
3. To remove the flange and locking ring:
 - a. Loosen setscrews D.
 - b. Loosen but do not remove capscrews E.
 - c. Remove key F. (This key projects a small amount to provide a grip for removing.)
 - d. Rotate the flange counterclockwise until it disengages the threads on the sheave barrel.
4. Verify that the driving and driven sheaves are in alignment and the shafts are parallel. When aligning two-groove sheaves, allow room between the sheave and motor to get to capscrews E.
5. Insert key C between the sheave and the shaft and tighten setscrew A securely.
6. If flange and locking ring have been removed, when replacing them make sure that the inner and outer flanges are open from the closed position by the same amount as the other flange. Determine this by accurately measuring the top width of the grooves.
7. Insert key F.
8. Tighten setscrews D and capscrews E.
9. Put on belts and adjust belt tension. Do not force belts over grooves. See [Fan Drive Belt Adjustment on page 50](#).
10. Be sure that all keys are in place and all setscrews and all capscrews are tight before starting the drive. Check and retighten all screws and retension belts after approximately 24 hours of service.

Adjusting:

1. Slack off belt tension if belts have been installed.
2. Loosen setscrews D.
3. Loosen but do not remove capscrews E.
4. Remove key F. (This key projects out a small amount to provide a grip for removing.)
5. Adjust pitch diameter by opening or closing the movable flanges by half or full turns. (Two-groove sheaves are supplied with both grooves set at the same pitch diameter.) Move both movable flanges the same number of turns to provide the same pitch diameter for satisfactory operation. Do not open sheaves more than five turns for A belts or six turns for B belts.
6. Replace key F.
7. Tighten setscrews D and capscrews E. 9 Verify that all keys are in place and all setscrews and all
8. If belts have been installed, readjust belt tension. If belts have not been installed, install them and adjust belt tension. **Do not force belts over grooves.** See [Fan Drive capscrews are tight before starting the drive. Check and retighten all screws and retension belts after approximately 24 hours of operation, \[Figure 53 on page 50\]\(#\).](#)

Figure 50: LVP Type Sheave Adjustment

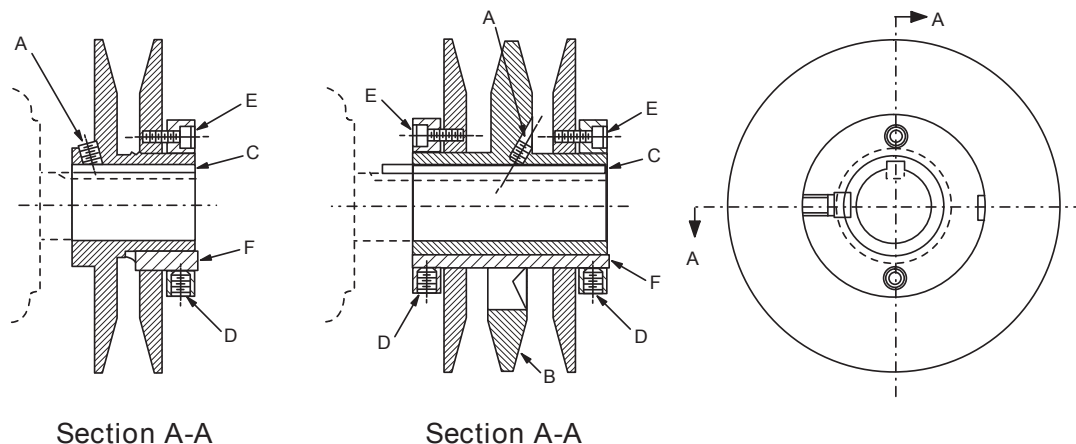

MVP Variable Speed Sheaves

Mounting:

1. Verify that both driving and driven sheaves are in alignment and the shafts are parallel. The centerline of the driving sheave must be in line with the centerline of the driven sheave. See [Figure 51](#).
2. Before starting drive, verify that all setscrews are torqued to the values shown in [Table 38 on page 51](#). Check setscrew torque and belt tension after 24 hours of service.

Adjusting:

1. Adjust motor base forward to release belt tension. For easier adjustment, remove the belts.
2. Loosen, but do not remove both of the locking setscrews A in the outer locking ring by using a hex key or torque wrench with a hex bit.
3. Adjust sheave to desired pitch diameter by turning the outer locking ring. Use a spanner wrench or drift inserted into the three holes that are located 120° apart on the ring.
4. Any pitch diameter can be obtained within the sheave range. One complete turn of the outer locking ring changes the pitch diameter 0.233".
5. Do not open sheaves more than the following amounts:
 - Do not open B sheaves more than 4, 3/4 turns for the A belts or 6 turns for the B belts.
 - Do not open C sheaves more than 9 1/2 turns.
 - Do not open 5V sheaves more than 6 turns.
 - Do not open 8V sheaves more than 8 turns.
6. Before operating the drive, tighten BOTH locking screws A in the outer locking ring. Use a torque wrench and tighten to the value shown in [Table 38 on page 51](#).
7. Replace belts and adjust the motor base to tension the belts properly. See [Fan Drive Belt Adjustment on page 50](#).
8. Do not loosen any screws other than the two locking screws A in the outer locking ring when adjusting the sheave pitch. Do not operate the drive until the locking screws are set to the torque specifications.

Figure 51: MVP Type Sheave Adjustment

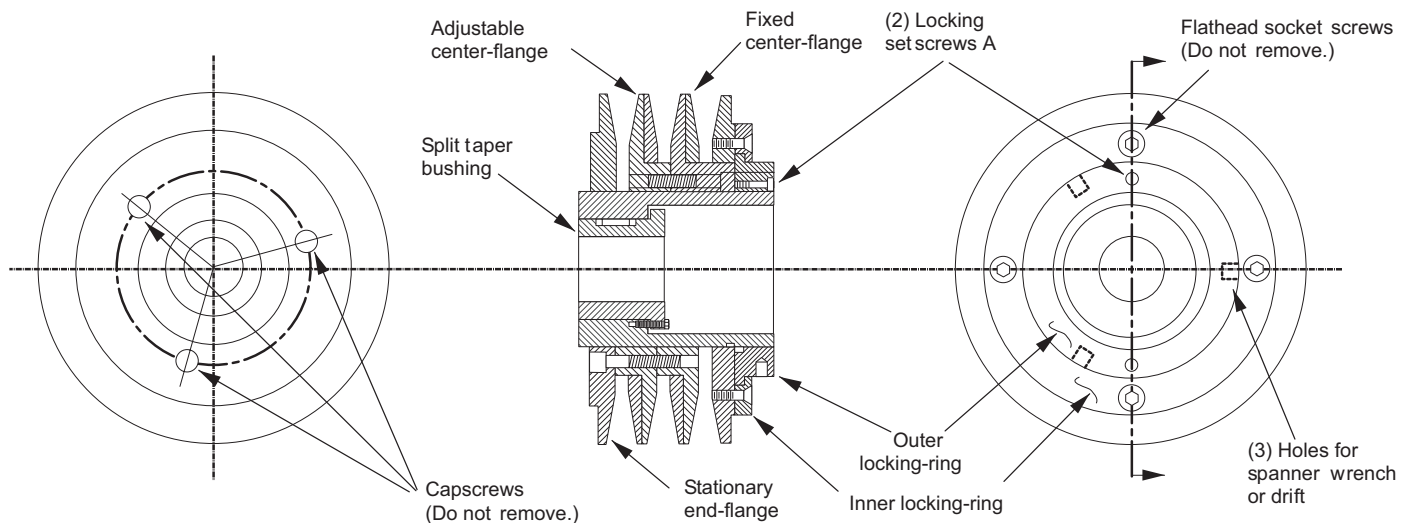

Fan Drive Belt Adjustment

WARNING

Moving belt and fan can cause severe personal injury or death.

During installation and filter maintenance:

- Lock and tag out fans to prevent accidental start up.
- Do not enter the filter compartment until the fan is completely stopped.
- Use approved equipment for reaching filters located above normal reach. Do not step on filter frames or unit components.
- Floor surfaces must be dry and free of oil or grease.

Figure 52: Sheave/Belt Alignment

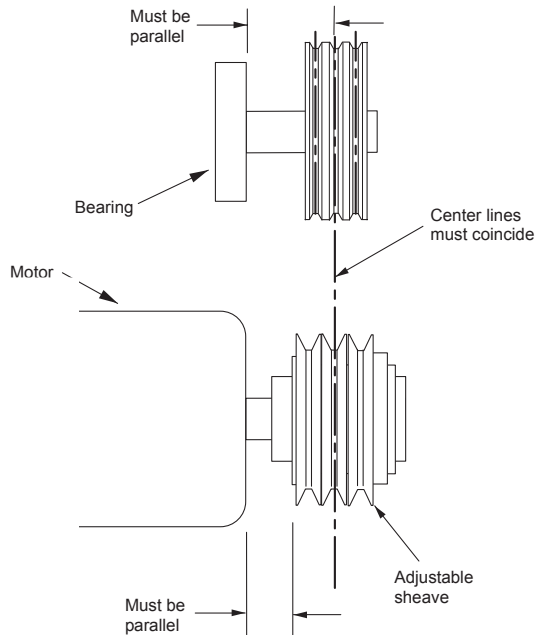

General Rules of Tensioning

1. The ideal tension is the lowest tension at which the belt does not slip under peak load conditions.
2. Check tension frequently during the first 24 to 48 hours of operation.
3. Over tensioning shortens belt and bearing life.
4. Keep belts free from foreign material, which may cause slippage.
5. Make V-drive inspection on a periodic basis. Adjust tension if the belt is slipping. Do not apply belt dressing. This may damage the belt and cause early failure.

Tension Measurement Procedure

1. Measure the belt span. See Figure 53.
2. Place belt tension checker squarely on one belt at the center of the belt span. Apply force to the checker, perpendicular to the belt span, until the belt deflection equals belt span distance divided by 64. Determine force applied while in this position.
3. Compare this force to the values in Table 38.
4. Adjust to the minimum value. If the belts slip, add tension.

Figure 53: Drive Belt Adjustment

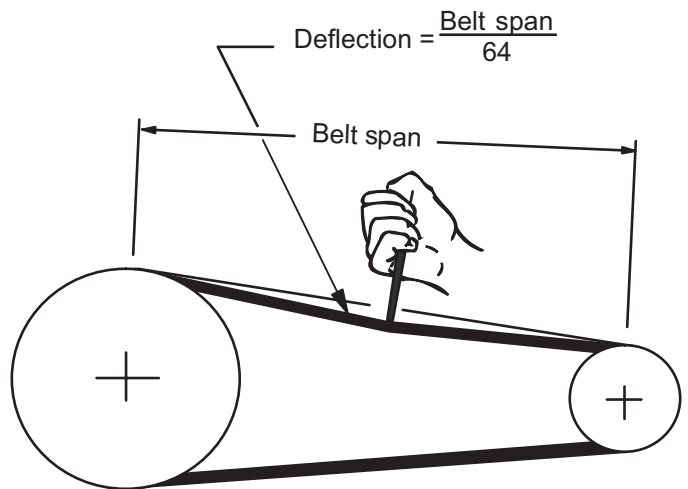

Table 37: Screw Torque Values

Nominal screw size, (dia-thds/in)	Socket head cap screws		Flat head socket screws	Hollow head setscrews only			
	Seating torque			Lengths equal or greater than diameter		For lengths (L) less than diameter	
	(in-lbs)	(ft-lbs)	(in-lbs)	(in-lbs)	(ft-lbs)	Length (L) (in)	Seating torque (in-lbs)
1/4-20NC	150	12.5	100	87	7.3	3/16	50
5/16-11NC	305	25.4	200	165	13.8	1/4	90
3/8-16NC	545	45.4	350	290	24.2	1/4, 5/16	150, 250
1/2-13NC	1300	108.3	N/A	620	51.7	N/A	N/A
5/8-11NC	N/A	N/A	N/A	1225	102.1	N/A	N/A

Table 38: Belt Deflection Force

Cross section	Sheave diameter (inches)		Deflection force (lbs)/belt deflection force			
	Smallest sheave diameter range	RPM range	Cross section A, B, 5V		Cross section AX, BX, 5VX	
			Min	Max	Min	Max
A, AX	3.0 to 3.6	1000 to 2500	2.8	5.5	3.0	6.1
		2501 to 4000	2.1	4.2	2.5	5.0
	3.8 to 4.8	1000 to 2500	3.4	6.8	3.7	7.4
		2501 to 4000	2.4	5.7	3.2	6.4
	5.0 to 7.0	1000 to 2500	4.0	8.0	4.7	9.4
		2501 to 4000	3.5	7.0	3.8	7.6
B, BX	3.4 to 4.2	850 to 2500	—	—	3.6	7.2
		2501 to 4000	—	—	3.1	6.2
	4.4 to 5.6	860 to 2500	4.0	7.9	5.2	10.5
		2501 to 4000	3.3	6.7	4.5	9.1
	5.8 to 8.6	860 to 2500	4.7	9.4	6.3	12.6
		2501 to 4000	4.5	8.9	5.4	10.9
5V, 5VX	4.4 to 6.7	500 to 1749	—	—	7.6	15.2
		1750 to 3000	—	—	6.6	13.2
		3001 to 4000	—	—	4.2	8.5
	7.1 to 10.9	500 to 1740	9.5	18.9	11.0	22.1
		1741 to 3000	8.3	16.7	10.0	20.1
	11.8 to 16.0	500 to 1740	11.7	23.4	12.7	25.5
1741 to 3000		10.5	21.8	12.5	25.0	

Coil Maintenance

WARNING

SHARP EDGES AND COIL SURFACES are a potential injury hazard. Avoid contact with them.

NOTICE

Clean drain pan regularly so mold does not develop.

1. For maximum performance, the coil must be clean.
Check once a year under normal operating conditions and brush or vacuum clean if necessary. Use a chemical coil cleaner on multiple row coils. Read and follow the chemical cleaner instructions since some cleaners may contain harsh chemicals. Take care not to damage fins while cleaning.
2. Drain pans in any air conditioning unit may have some moisture. Algae and other organisms can grow due to airborne spores and bacteria. Clean periodically to prevent build-up from plugging the drain and causing the drain pan to overflow. Keep drain pans clean to prevent the spread of disease. Cleaning should be performed by qualified personnel
3. Dirt and lint can clog the condensate drain, especially with dirty filters. Inspect twice a year to help avoid overflow.

Component Removal and Replacement

Panel Removal

Remove the screws located along the sides of the panel. Pull the panel out using the pocket pull handles. If the panel does not have a pull handle, remove the adjacent panel with a pocket pull or door and pop out the panel from the inside.

Fan Section Removal

The fan shaft, motor and any drive components are removable through the access door or panel opening.

If fan replacement is required, the entire fan assembly can be pulled out the side of the cabinet. The fan assembly includes the fan housing, the bearing support and the fan base.

1. To remove the fan assembly, remove the side panels (follow instructions for side panel removal).
2. Disconnect the neoprene bulkhead seal that is attached to the fan discharge. Then disconnect the fan sled from each of the corner mounts and pull the entire assembly out the side of the unit.
3. Loosen the fan bearings and pull out the shaft. Disconnect the fan housing from the fan sled and bearing support by removing the attaching bolts.
4. Replace the new fan, reconnect the shaft and bearings and put the fan assembly in the cabinet. Replace panels and fasteners.

Coil Removal and Replacement

Before removing the coil, disconnect all piping.

1. Remove exterior panels from both sides of the coil section. Remove screws that secure the top of the leaving coil face to the upper track on the inside top of the unit.
2. Lift drain pan condensate connection above the unit frame flange and slide drain pan, coil(s), and baffles out of unit.
3. Slide the coil, blockoffs, and drain pan assembly back into unit the same way it was removed. Check the installation for an airtight fit.
4. Reinstall screws that secure the top of the leaving coil face to the upper track on the inside top of the unit.

Figure 54: Coil Removal

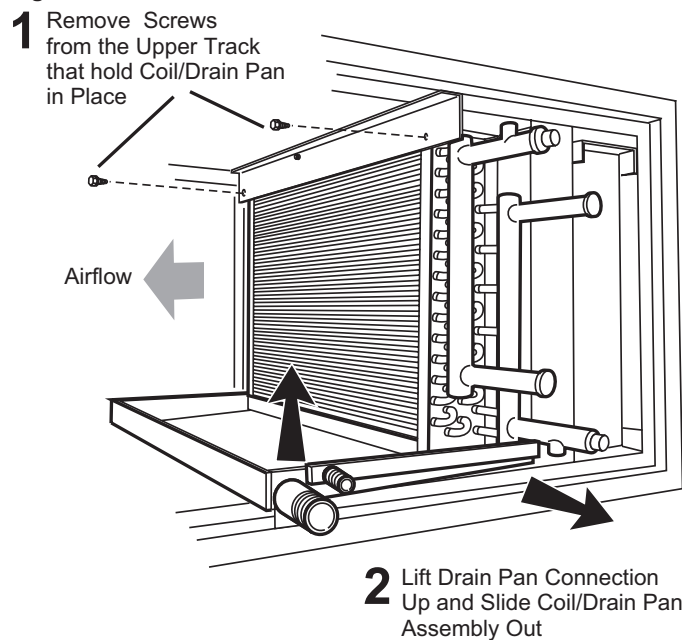

Warranty Details

Consult your local Daikin representative for warranty details. To find your local Daikin representative, go to www.DaikinApplied.com.

Warranty Return Material Procedure

Defective material may not be returned without permission of authorized factory service personnel of Daikin Applied in Minneapolis, Minnesota, (763) 553-5330. A "Return Goods" tag must be included with the returned material. Enter the required information to expedite handling and prompt issuance of credits. All parts must be returned to the appropriate Daikin facility, designated on the "Return Goods" tag. Transportation charges must be prepaid.

The return of the part does not constitute an order for replacement. Therefore, a purchase order must be entered through the nearest Daikin representative. The order should include part number, model number, and serial number of the unit involved.

Credit will be issued on customer's purchase order following an inspection of the return part and upon determination that the failure is due to faulty material or workmanship during the warranty period.

Replacement Parts

When writing to Daikin Applied for service or replacement parts, refer to the model number and serial number of the unit stamped on the serial plate attached to the unit. If replacement parts are required, mention the date of installation of the unit and date of failure, along with an explanation of the malfunctions and a description of the replacement parts required.



Air Handling Equipment Warranty Registration Form

To comply with the terms of Daikin Applied Warranty, complete and return this form within 10 days to the Warranty Department of Daikin Applied.

Check, test, and start procedure for air handling units with or without heat recovery and roof mounted air handlers.

GENERAL INFORMATION

Job Name: _____ GOI No.: _____

Installation address: _____

City: _____ State: _____

Purchasing contractor: _____

City: _____ State: _____

Name of person doing start-up: _____

Company name: _____

Address: _____

City/State/Zip: _____

UNIT INFORMATION

Unit model number: _____ Unit serial number: _____

SF VFD model number: _____ Serial number: _____

RF VFD model number: _____ Serial number: _____



AHU Equipment Warranty Registration Form (continued)

Select Yes or No. If not applicable to the type of unit, select N/A.

I. INITIAL CHECK

- A. Is any shipping damage visible? Yes No N/A
- B. Are fan drives properly aligned and belts properly adjusted? Yes No N/A
- C. Tightened all setscrews on pulleys, bearings and fans? Yes No N/A
- D. Have the hold-down bolts been backed off on spring mounted fan isolators? Yes No N/A
- E. With the power off, do fans turn freely by hand? Yes No N/A
- F. Electrical service corresponds to unit nameplate? Yes No N/A

Volts _____ Hertz _____ Phase _____

- G. Is the main disconnect adequately fused and are fuses installed? Yes No N/A
- H. Are all electrical power connections tight? (Check compressor, electrical box.) Yes No N/A
- I. Is the condensate drain trapped? Yes No N/A
- J. Fill the drain pan. Does water drain freely? Yes No N/A
- K. Is the unit mounted level? Yes No N/A

II. FAN DATA

- A. Check rotation of supply fan? Yes No N/A
- B. Voltage at supply fan motor: 1-2 _____ V 2-3 _____ V 1-3 _____ V
- C. Supply fan motor amp draw per phase: L1 _____ L2 _____ L3 _____
- D. Overload amp setting: _____
- E. What is the supply fan rpm? _____
- F. Check rotation of return fan? Yes No N/A
- G. Voltage at return fan motor: 1-2 _____ V 2-3 _____ V 1-3 _____ V
- H. Return fan motor amp draw per phase: L1 _____ L2 _____ L3 _____
- I. Overload amp setting: _____
- J. What is the return fan rpm? _____
- K. Record supply static pressure at unit in inches of H₂O: _____
- L. Record return static pressure at unit (with outside air dampers closed) in inches of H₂O: _____

III. DAMPERS

- A. Are blades and seals present? Yes No N/A
- B. Do damper open smoothly and shut tight? Yes No N/A



AHU Equipment Warranty Registration Form (continued)

Select Yes or No. If not applicable to the type of unit, select N/A.

IV. ELECTRIC HEAT

A. Electrical heat service corresponds to unit nameplate? Yes No N/A

Volts _____ Hertz _____ Phase _____

B. Are there any signs of physical damage to the electric heat coils? Yes No N/A

C. Have all electrical terminals been tightened? Yes No N/A

D. Does sequence controller stage contactors properly? Yes No N/A

E. Electric heater voltage across each phase: _____ L1 _____ L2 _____ L3

F. Amp draw across each phase at each heating stage:

	Stage 1	Stage 2	Stage 3	Stage 4	Stage 5	Stage 6
Phase L1: _____	_____	_____	_____	_____	_____	_____
Phase L2: _____	_____	_____	_____	_____	_____	_____
Phase L3 _____	_____	_____	_____	_____	_____	_____

G. FLA: L1 _____ L2 _____ L3 _____

H. Operate electric heat with fans off. Electric heat must cycle on high limit control Yes No N/A

V. CHILLED WATER COIL

A. Pressure test OK? Yes No N/A

B. Drain pan draining OK? Yes No N/A

VI. HOT WATER COIL

A. Pressure test OK? Yes No N/A

VII. HEAT RECOVERY

A. Heat wheel rotates freely? Yes No N/A

B. Heat wheel VFD operates properly? Yes No N/A

C. Heat wheel VFD: Model # _____ Serial # _____

D. Check for air bypass around heat wheel. Yes No N/A



AHU Equipment Warranty Registration Form (continued)

VIII. Design Flow calibration

- A. Verify power is supplied to the MicroTech III unit controller Yes No N/A
- B. Verify that the shipping screws have been removed from the measuring station vane Yes No N/A
- C. Examine station for damage Yes No N/A

D. Record Level Position after calibration

- LH Level Position _____
- RH Level Position _____

NOTE: This is viewed in the MicroTech III controller, in the Min OA setup menu.

IX. GAS BURNER CHECK, TEST, & START

Specifications:

For gas, see Forced Draft Gas Burner Installation and Maintenance Bulletin. (IM 684 and IM 685)

- A. Gas Furnace: Model no. _____
- B. Gas Burner: Model no. _____ Serial no. _____
- C. Gas Type firing: Single Stage _____ Modulation _____
- D. Gas Rated firing rate (MBH input): _____
- E. Gas Altitude (ft. above sea level): _____
- F. Is there a circulating tank? Yes No N/A
- G. Input (CFH): _____
- H. Gas pressure at burner (inches w.c.): _____
- I. CO₂ (%): _____
- J. CO₂ (%): _____
- K. Pilot flame only in microamps (steady at low fire): _____
- L. Pilot Tap-gas pressure (inches w.c.): _____
- M. Motor only/burner FLA running amps: _____
- N. High limit control OK? Yes No N/A
- O. Flame safeguard (microamps): _____
- P. Flame failure shutoff (seconds): _____

**AHU Equipment Warranty Registration Form (continued)**

Select Yes or No. If not applicable to the type of unit, select N/A.

Q. Airswitch OK?	Yes	No	N/A
R. High Gas Pressure Switch OK?	Yes	No	N/A
S. Low Gas Pressure Switch OK?	Yes	No	N/A
T. Main Gas Valve Close-off OK?	Yes	No	N/A

Thank you for completing this form. Please sign and date below.

Signature _____ Startup date: _____

Return completed form by mail to:

Daikin Warranty Department, 13600 Industrial Park Boulevard, Minneapolis, MN 55441

or by email to: AAH.Wty_WAR_forms@daikinapplied.com

Please fill out the Daikin Applied "Quality Assurance Survey Report" and list any additional comments that could affect the operation of this unit; e.g., shipping damage, failed components, adverse installation applications, etc. If additional comment space is needed, write the comment(s) on a separate sheet, attach it to the Survey Report and return it to the Warranty Department of Daikin Applied with the completed Equipment Warranty Registration form.



Quality Assurance Survey Report

To whom it may concern:

Please review the items below upon receiving and installing our product. Select N/A on any item that does not apply to the product.

Job Name: _____ **Daikin Applied G.O. No.** _____

Installation address: _____

City: _____ State: _____

Purchasing contractor: _____

City: _____ State: _____

Name of person doing start-up (print): _____

Company name: _____

Address: _____

City/State/Zip: _____

Unit model number: _____ **Unit serial number:** _____

1. Is there any shipping damage visible? Yes No N/A

Location on unit _____

2. How would you rate the overall appearance of the product; i.e., paint, fin damage, etc.? Excellent Good Fair Poor

3. Did all sections of the unit fit together properly? Yes No N/A

4. Did the cabinet have any air leakage? Yes No N/A

Location on unit _____

5. Were there any refrigerant leaks? Yes No N/A

From where did it occur? Shipping Workmanship Design

6. Does the refrigerant piping have excessive vibration? Yes No N/A

Location on unit _____

7. Did all of the electrical controls function at start-up? Yes No N/A

Comments _____

8. Did the labeling and schematics provide adequate information? Yes No N/A

9. How would you rate the serviceability of the product? Excellent Good Fair Poor

10. How would you rate the overall quality of the product? Excellent Good Fair Poor

11. How does the quality of Daikin Applied products rank in relation to competitive products? Excellent Good Fair Poor

Comments _____

Please list any additional comments which could affect the operation of this unit; i.e., shipping damage, failed components, adverse installation applications, etc. If additional comment space is needed, write the comment(s) on a separate sheet, attach the sheet to this completed Quality Assurance Survey Report, and return it to the Warranty Department with the completed preceding "Equipment Warranty Registration Form".



Daikin Applied Training and Development

Now that you have made an investment in modern, efficient Daikin equipment, its care should be a high priority. For training information on all Daikin HVAC products, please visit us at www.DaikinApplied.com and click on Training, or call 540-248-9646 and ask for the Training Department.

Warranty

All Daikin equipment is sold pursuant to its standard terms and conditions of sale, including Limited Product Warranty. Consult your local Daikin Applied Representative for warranty details. To find your local Daikin Applied Representative, go to www.DaikinApplied.com.

Aftermarket Services

To find your local parts office, visit www.DaikinApplied.com or call 800-37PARTS (800-377-2787). To find your local service office, visit www.DaikinApplied.com or call 800-432-1342.

This document contains the most current product information as of this printing. For the most up-to-date product information, please go to www.DaikinApplied.com.

Products manufactured in an ISO Certified Facility.